



Water chillers

AQUACIAT 2

High energy efficiency with
R410A
 Compact and quiet
Scroll compressors
 Brazed plate heat exchangers
 Self adjusting electronic **control system**



Cooling capacity: 20 to 290 kW
 Heating capacity: 20 to 285 kW



Cooling or heating



Hydraulic pack



Heat recovery



USE

The **AQUACIAT 2 series LD-LDC-LDH** or **ILD-ILDC-ILDH** water chillers or heaters with air-cooled condensers are medium capacity units particularly adapted for heating and air conditioning applications in the fields of Offices, Healthcare, Industry, Administration, Commercial and Residential buildings.

These standard packaged units are designed for outdoor installation; no particular precautions have to be taken against adverse weather conditions.

An optional XTRAFAN version allows if necessary the possibility of mounting an air duct on the fan(s) discharge in the case of air recycling risk or for an acoustic treatment on site.

To operate in **COOLING** or **HEATING** mode, these units use outside air as the only external source; this permits the evacuation of heat in summer or the supply of thermal energy for heating in winter.

Connected to a heating or cooling floor, to fan coil units or to an air handling unit, the reversible Aquaciat 2 Series **ILD-ILDC-ILDH** permits easy heating and air conditioning of buildings.

Each unit is assembled, electrically wired (control and capacity), charged with refrigerant, and tested in factory.

The installation is very simple and the only operations to be carried out on site are the electrical wiring and water connections.

RANGE

AQUACIAT 2 series LD

Cooling only chillers without hydraulic equipment.

AQUACIAT 2 series LDC - LDH

Cooling only chillers with hydraulic equipment, water pump only, or pump and buffer tank.

AQUACIAT 2 series ILD

Reversible air/water cooled models without hydraulic equipment.

AQUACIAT 2 series ILDC - ILDH

Reversible air/water cooled models with hydraulic equipment (circulating water pump only or pump and buffer tank).

DESCRIPTION

The standard **AQUACIAT 2 series LD-LDC-LDH (cooling only)** or **series ILD-ILDC-ILDH (reversible)** are delivered with the following components:

- air-cooled condenser with propeller fan motor assembly,
 - chilled water evaporator (or hot water condenser on reversible models),
 - capacity control system on chilled or hot water,
 - starting automatic control, electrical compartment:
 - . Power supply : 3~50Hz 400V (+6%/- 10%) + earth
 - . Control circuit: 1~50Hz 230V
- (transformers are mounted on the unit in the standard version),
- cabinet for outdoor installation.



80 to 300

■ Conformity with the EC European directives

- Machines EC 98 / 37
- Electromagnetic EMC 2004/108/CE
- Under pressure equipment DESP EC 97 / 23:
 - category 2 for LD - LDC - LDH 80V à 1100V
 - category 2 for ILD - ILDC - ILDH 80V à 700V
 - category 3 for ILD - ILDC - ILDH 702V à 1100V
- Low voltage 2006/95/CE

■ Conformity to standards

- EN 60-204 , EN 378-2 (NFC15 - 100 France).

NOMENCLATURE

ILD	>	reversible version	H	>	hydraulic version with pump and buffer tank
LD	>	cooling only model	540	>	size
C	>	hydraulic version with pump	V	>	refrigerant R410A

STANDARD OR OPTIONAL EQUIPMENT

	LD	LDC-LDH	ILD	ILDC - ILDH
	COOLING ONLY		HEAT PUMP	
3-400V 50hz main supply without neutral with transformer	Std	Std	Std	Std
Coil protective grille	Std ➔ 300	Std ➔ 300	Std ➔ 300	Std ➔ 300
Resilient mounts	Std	Std	Std	Std
Main switch	Std	Std	Std	Std
Water flow switch	Std	Std	Std	Std
Additional potential free contacts board	O	O	O	O
Remote control (Remote console)	O	O	O	O
Phases control system (direction, absence, under & over voltage)	O	O	O	O
Progressive soft start	O	O	O	O
Anti-frost protection	O	O	O	O
All year round operation (min. outdoor temp.: -15°C)	Std	Std	Std	Std
Condenser fan speed control (min. outdoor temp.: -20°C)	O	O	O	O
Partial heat recovery -Desuperheater	O	O	O	O
BLYGOLD coil protective coating	O	O	O	O
Polyurethane fin protective coating	O	O	O	O
Water filter - 800 µm	O	Std	O	Std
Water adjustment kit (manifold, control valve, stop valve)	O	O	O	O
Flexible water connections	O	O	O	O
Twin pump	-	O / 180 ➔ 1100	-	O / 180 ➔ 1100
Additional technical compartment (without equipment)	O / 180 ➔ 300	O / 180 ➔ 300	O / 180 ➔ 300	O / 180 ➔ 300
Electric auxiliary heater kit 15 kW	-	-	O / 80 ➔ 150	O / 80 ➔ 150
Electric auxiliary heater module 15 - 30 - 45 kW	-	-	O / 180 ➔ 300	O / 180 ➔ 300
MULTICONNECT several units management	O	O	O	O
Auxiliary external heater management board (4 stages)	-	-	O	O
XTRAFAN air fans system	O / ➔ 700	O / ➔ 700	O / ➔ 700	O / ➔ 700
Low temperature glycol/water reinforced insulation (0 to -12°C)	O / 350 ➔	O / 350 ➔	O / 350 ➔	O / 350 ➔
LONWORKS communication gateway	O	O	O	O
Handling for container	350 ➔ 1100	350 ➔ 1100	350 ➔ 1100	350 ➔ 1100
Optimised high pressure operation (all-season operation with energy optimisation)	O / 350 ➔ 1100	O / 350 ➔ 1100	-	-
Electronic expansion valve	O / 350 ➔ 1100	O / 350 ➔ 1100	-	-
Total heat recovery	O / 350 ➔ 1100	O / 350 ➔ 1100	-	-

Std: Standard feature

O: Optional equipment

-: Not available

Note: Some technical specifications not appearing on the above list can however be quoted on request (consult us)



Water chillers

COOLING ONLY - TECHNICAL CHARACTERISTICS



LD - LDC - LDH		80V	90V	100V	120V	150V	180V	200V	240V	300V	
Cooling capacity ①	kW	19.7	22.4	26.3	29.9	38.9	46.7	53.1	61.0	76.8	
Power input	kW	6.9	8.1	9	10.6	13.7	14.8	18.1	20.5	27.7	
EER Efficiency ②		2.84	2.78	2.93	2.82	2.84	3.15	2.94	2.97	2.77	
Seasonal efficiency ESEER		3.34	3.25	3.51	3.26	3.28	4.51	4.33	4.02	3.97	
Lw / Lp ③ (High Perf. - HP)	dB(A)	75/43		79/47		80/48		81/49		86/54	
Lw / Lp ③ (Low Noise version - LN)	dB(A)	71/39		75/43		77/45		79/47		82/50	
Compressor		Hermetic SCROLL 2900 rpm									
Starting mode		Direct in series									
Quantity		1				2					
Capacity control	%	100-0				100-50-0					
Refrigerant oil type		Polyolester POE 3MAF (32cst)									
Oil volume	l	2.50	3.25	3.25	3.25	4.14	6.50	6.50	6.50	8.30	
Refrig. circuit number		1									
Refrigerant fluid (GWP)		R410A (1890)									
Refrigerant load	kg	5.3	5.5	7.2	7.3	7.8	13.2	13.5	14.2	14.2	
Electric supply	ph/Hz/V	3~50Hz 400V (+6%/-10%) + Earth									
Unit protection index		IP 44									
Control voltage	ph/Hz/V	1~50Hz 230V (+6%/-10%) - transformer mounted									
Evaporator		Braze plates type exchanger									
Water content	l	1.78	1.78	2.22	2.22	3.11	3.55	4.22	4.77	7.71	
Chilled water outlet min/max	°C	-12 / +15									
Minimum water flow	m³/h	2.9	2.9	3.6	3.6	5.1	5.8	6.9	7.8	10.4	
Maximum water flow	m³/h	6.7	7.4	9.0	10	13.1	15.4	17.6	20.4	24.5	
Water connections	≥	Male G 1 1/4"		Male G 1 1/2"			Male G 2"				
Maximum pressure (water side)	bar	LD 10 bars / LDC-LDH 4 bars									
Air cooled condenser		Finned heat exchanger									
Fan ≥	mm	710			800						
No. x Motor rated power High Performance series - HP	nb x kW	1x0.5	1x0.5	1x0.9	1x0.9	1x0.9	1x0.9	1x0.9	1x1.7	1x1.7	
No. x Motor rated power Low Noise series - LN	nb x kW	1x0.35	1x0.35	1x0.46	1x0.46	1x0.46	1x0.46	1x0.46	1x1.2	1x1.2	
High Performance air flow - HP	m³/h	10800	10800	16700	16700	15500	16100	16100	24000	24000	
Low Noise air flow - LN	m³/h	8700	8700	10800	10800	9700	10800	10800	18000	18000	
Mini water content (ILD-ILDC)	l	114	130	155	173	229	131	149	173	209	
Water tank content H model	l	100		150			200				
Expansion vessel C & H model	l	6			12						
Standard pump	n°	44	44	44	44	45	40	40	40	41	
Height without mounts	mm	1170			1393			1743			
Standard series length	mm	1995			1995			1995			
C series length	mm	1995			1995			1995			
H series length	mm	1995			1995			2676			
Depth	mm	1055			1055			1055			
Std range weight without charge	kg	326	329	365	367	449	564	570	576	706	
C range weight without charge	kg	344	347	383	385	467	611	614	620	751	
H range weight without charge	kg	369	372	407	409	492	808	811	817	948	
Storage temperature	°C	+ 50°C									

① Capacities of HIGH PERFORMANCE series based on:EUROVENT conditions (EN 14511)

COOLING mode: +12°C/+7°C and condenser air inlet temperature +35°C

② EER in gross values

③ Total Sound power Lw, total sound pressure at 10 m from the unit, in free field, conformity with ISO 3744 norm

④ According to selection.



COOLING ONLY - TECHNICAL CHARACTERISTICS



LD - LDC - LDH		350V	400V	500V	540V	600V	700V	702V	800V	900V	1000V	1100V	
Cooling capacity ①	kW	92.5	102.6	123.9	135.9	151.1	173.3	189.3	209.9	250.9	270.6	291.5	
Power input	kW	30.9	36.1	46.2	47.5	55.8	64.4	60.3	69.7	81.5	89.6	100.2	
EER Efficiency ②		2.99	2.84	2.68	2.80	2.71	2.69	3.14	3.01	3.08	3.02	2.91	
Seasonal efficiency ESEER		4.16	3.85	3.36	3.90	3.91	3.70	4.24	4.12	4.11	4.08	3.98	
Lw / Lp ③ (High Perf. - HP)	dB(A)	89/57	90/58		90/58	91/59		89/57	90/58				
Lw / Lp ③ (Low Noise version - LN)	dB(A)	83/51			85/53			84/52	85/53	84/52		85/53	
Lw / Lp ③ (Xtra Low Noise version - XLN)	dB(A)	-	-	-	-	-	-	81/49	82/50	81/49	81/49	83/51	
Compressor		Polyolester SCROLL 2900 rpm											
Starting mode		Direct in series											
Quantity		2	2	2	4	4	4	4	4	4	4	4	
Capacity control	%	100-57-43-0	100-63-37-0	100-50-0	100-78-72-55-50-45-28-22-0	100-75-50-25-0	100-78-71-57-50-43-28-21-0		100-81-69-62.5-50-37.5-31-19-0	100-83-66-55-33-16-0	100-80-70-60-50-40-30-20-0	100-77-73-54-50-45-27-23-0	
Refrigerant oil type		Polyolester POE 3MAF (32cst)											
Oil volume	l	8.8	9.8	11.2	14.8	16.6	17.6	17.6	21.8	20.8	22.2	26.2	
Refrig. circuit number		1			2								
Refrigerant fluid (GWP)		R410A (1890)											
Refrigerant load	kg	18.5	18	11.8 +11.8	13.0 +13.5	13.2 +13.7	17.8 +17.8	18.0 +18.0	17.0 +17.0	21.0 +21.0	22.0 +22.0	23.0 +23.0	
Electric supply	ph/Hz/V	3~50Hz 400V (+6%/-10%) + Earth											
Unit protection index		IP 44											
Circuit control voltage	ph/Hz/V	1~50Hz 230V (+6%/-10%) - transformer mounted											
Evaporator		Brazen plates type exchanger											
Water content	l	8.68	9.88	10.66	12.48	15.42	15.42	15.8	15.8	18	20.4	20.4	
Chilled water outlet min. / max.	°C	-12 / +18											
Minimum water flow	m³/h	11.7	13.3	17.3	18.1	20.8	20.8	22.1	24.4	29.3	31.6	34	
Maximum water flow	m³/h	30.7	34.6	41.9	45.9	50.7	50.7	63.2	69.5	77	77	77	
Water connections	≥	Male G 2 1/4"			Flange DN80			Flange DN100					
Maximum pressure (water side)	bar	LD 10 bars / LDC-LDH 4 bars											
Air cooled condenser		Finned heat exchanger											
Fan ≥	mm	800											
Number x Motor rated power High Performance series- HP	nb x kW	2x1.7	2x1.7	2x1.8	2x1.7	2x1.7	2x1.7	4x1.55	4x1.55	4x1.66	4X1.66	4X1.66	
Number x Motor rated power Low Noise series - LN	nb x kW	2x1.6	2x1.2	2x1.2	2x1.1	2x1.1	2x1.1	4x1.06	4x1.06	4x1.1	4x1.1	4x1.1	
High Performance air flow - HP	m³/h	44000	42000	41000	44000	44000	44000	81200		78000			
Low Noise air flow - LN - XLN	m³/h	32000	29000	30500	35000	35000	35000	60000		58400			
Mini water content (ILD-ILDC)	l	220	213	357	164	207	203	213	212	213	290	364	
Water tank content H model	l	250					500						
Expansion vessel C & H model	l	18					35						
Standard pump	n°	④											
Height without mounts	mm	2117			2117			2080 (+ 205 XLN)					
Standard series length	mm	2190			2740			3698					
C series length	mm	2190			2740			3698					
H series length	mm	2190			2740			3698					
Depth	mm	2129			2129			2200					
Std range weight without charge	kg	1046	1145	1183	1460	1596	1768	2135	2175	2215	2255	2310	
C range weight without charge	kg	1144	1242	1254	1654	1775	1947	2360	2400	2455	2495	2625	
H range weight without charge	kg	1207	1306	1318	1718	1838	2010	2510	2550	2605	2645	2745	
Storage temperature	°C	+ 50°C											

① Capacities of HIGH PERFORMANCE series based on:EUROVENT conditions (EN 14511)

COOLING mode: +12°C/+7°C and condenser air inlet temperature +35°C

② EER in gross values

③ Total Sound power Lw, total sound pressure at 10 m from the unit, in free field, conformity with ISO 3744 norm

④ According to selection.



REVERSIBLE UNIT - HEAT PUMP TECHNICAL CHARACTERISTICS



ILD - ILDC - ILDH		80V	90V	100V	120V	150V	180V	200V	240V	300V	
Cooling capacity ①	kW	20.2	22.9	27.4	30.5	40.5	47.1	53.5	61.9	75.6	
Power input	kW	6.9	8.0	9.1	10.6	13.0	15.2	18.3	20.7	27.6	
EER Efficiency ②		2.93	2.86	3.01	2.88	3.12	3.10	2.92	2.99	2.74	
Seasonal efficiency ESEER		3.31	3.22	3.42	3.25	3.50	4.22	4.20	3.89	3.84	
Lw / Lp ③ (High Perf. - HP)	dB(A)	75/43		79/47		80/48	81/49		86/54	89/57	
Lw / Lp ③ (Low Noise version - LN)	dB(A)	71/39		75/43		77/45	79/47	78/46	82/50	83/51	
Heating capacity ①	kW	20.7	23.2	28.1	31.6	41.4	48.4	54.9	63.7	81.4	
Power input	kW	7.0	7.9	9.6	10.7	13.6	15.4	17.9	20.9	26.3	
Performances COP ②		2.95	2.93	2.93	2.95	3.04	3.10	3.07	3.05	3.10	
Compressor		Hermetic SCROLL 2900 rpm									
Starting mode		Direct in series									
Quantity		1				2					
Capacity control	%	100-0				100-50-0					
Refrigerant oil type		Polyolester POE 3MAF (32cst)									
Oil volume	l	2.50	3.25	3.25	3.25	4.14	6.50	6.50	6.50	8.30	
Refrig. circuit number		1									
Refrigerant fluid (GWP)		R410A (1890)									
Refrigerant load	kg	6.5	6.1	8.2	9.8	11.3	17.2	17			
Electric supply	ph/Hz/V	3-50Hz 400V (+6%/-10%) + Earth									
Unit protection index		IP 44									
Circuit control voltage	ph/Hz/V	1~50Hz 230V (+6%/-10%) - transformer mounted									
Evaporator		Brazed plate type exchanger									
Water content	l	1.78	1.78	2.22	2.22	3.11	3.55	4.22	4.77	7.71	
Chilled water outlet min. / max.	°C	-10 / +15									
Hot water outlet min. / max.	°C	+30 / +50									
Minimum water flow	m³/h	2.9	2.9	3.6	3.6	5.1	5.8	6.9	7.8	10.4	
Maximum water flow	m³/h	6.7	7.4	9.0	10	13.1	15.4	17.6	20.4	24.5	
Water connections	≥	Male G 1 1/4"		Male G 1 1/4"			Male G 2"				
Maximum pressure (water side)	bar	ILD 10 bars / ILDC-ILDH 4 bars									
Air cooled condenser		Finned heat exchanger									
Fan ≥	mm	710			800						
Number x Motor rated power High Performance series - HP	nb x kW	1x0.5	1x0.5	1x0.9	1x0.9	1x0.9	1x0.9	1x0.9	1x1.7	1x1.7	
Number x Motor rated power Low Noise series - LN	nb x kW	1x0.35	1x0.35	1x0.46	1x0.46	1x0.46	1x0.46	1x0.46	1x1.2	1x1.2	
High Performance air flow - HP	m³/h	10800	10800	16700	16700	15500	16100	16100	24000	24000	
Low Noise air flow - LN	m³/h	8700	8700	10800	10800	9700	10800	10800	18000	18000	
Mini water content (ILD-ILDC)	l	114	130	155	173	229	131	149	173	209	
Water tank content model H	l	100		150			200				
Expansion vessel C & H model	l	6			12						
Standard pump	n°	44		44	44	45	40	40	40	41	
Height without mounts	mm	1170			1393			1743			
Standard series length	mm	1995			1995			1995			
C series length	mm	1995			1995			1995			
H series length	mm	1995			1995			2676			
Depth	mm	1055			1055			1055			
Std range weight without charge	kg	328	331	366	368	452	611	614	620	756	
C range weight without charge	kg	346	349	384	386	470	648	651	656	789	
H range weight without charge	kg	371	374	409	411	495	845	848	853	986	
Storage temperature	°C	+ 50°C									

① Capacities of HIGH PERFORMANCE series based on:EUROVENT conditions (EN 14511)

a/ COOLING : +12°C/+7°C and air inlet temp. at condenser +35°C

b/ HEATING: hot water outlet +45°C and outdoor air +7°C DB 86%RH

② EER and COP are gross values

③ Total sound power Lw, total sound pressure at 10 m from the unit, in free field, conformity with ISO 3744 norm



REVERSIBLE UNIT - HEAT PUMP TECHNICAL CHARACTERISTICS



ILD - ILDC - ILDH		350V	400V	500V	540V	600V	700V	702V	800V	900V	1000V	1100V	
Cooling capacity ①	kW	92.8	105.2	128.1	139.9	155.3	163.1	183,4	201,8	239,8	257,9	278,8	
Power input	kW	31.4	35.2	44.4	46.1	52.5	59.5	61,5	69,8	83,0	91,9	101,5	
EER Efficiency ②		2.96	2.98	2.88	3.03	2.96	2.74	2,98	2,89	2,89	2,81	2,75	
Seasonal efficiency ESEER		3.70	3.84	3.27	3.97	3.95	3.63	3,83	3,81	3,75	3,77	3,63	
Lw / Lp ③ (High Perf. - HP)	dB(A)	89/57	90/58			91/59			92/60				
Lw / Lp ③ (Low Noise version - LN)	dB(A)	83/51			85/53				87/55				
Lw / Lp ③ (Xtra Low Noise version - XLN)	dB(A)	-	-	-	-	-	-	81/49	82/50	81/49	81/49	83/51	
Heating capacity ①	kW	95.0	108.8	132.6	147.1	164.0	181.5	191,1	213,5	247,9	265,2	285,7	
Power input	kW	31.4	36.0	43.1	47.7	53.0	57.1	63,2	71,5	82,7	89,9	97,1	
Performances COP ②		3.03	3.02	3.07	3.08	3.09	3.12	3,02	2,99	3,00	2,95	2,94	
Compressor	Hermetic SCROLL 2900 rpm												
Starting mode	Direct in series												
Quantity		2	2	2	4	4	4	4	4	4	4	4	
Capacity control	%	100-57-43-0	100-63-37-0	100-50-0	100-78-72-55-50-45-28-22-0	100-75-50-25-0	100-78-50-22-0	100-78-71-57-50-43-28-21-0	100-81-69-62.5-50-37.5-31-19-0	100-83-66-55-33-16-0	100-80-70-60-50-40-30-20-0	100-77-73-54-50-45-27-33-0	
Refrigerant oil type	Polyolester POE 3MAF (32cst)												
Oil volume	l	8.8	9.8	11.2	14.8	16.6	17.6	17.6	21.8	20.8	22.2	26.2	
Refrig. circuit number		1			2								
Refrigerant fluid (GWP)	R410A (1890)												
Refrigerant load	kg	21	24	13.0 +13.0	18.0 +18.0	18.2 +19.2	19.5 +19.5	24.2 +23.8	25.4 +25	27 +26.3	27.7 +27	28.5 +27.8	
Electric supply	ph/Hz/V	3~50Hz 400V (+6%/-10%) + Earth											
Unit protection index	IP 44												
Circuit control voltage	ph/Hz/V	1~50Hz 230V (+6%/-10%) - transformer mounted											
Evaporator	Brazed plates type exchanger												
Water content	l	8.68	9.88	10.66	12.48	15.42	15.42	15.8	15.8	18	20.4	20.4	
Chilled water outlet min. / max.	°C	-10 / +18						-12 / +18					
Hot water outlet min. / max.	°C	+30 / +50											
Minimum water flow	m³/h	11.7	13.3	17.3	18.1	20.8	20.8	22.1	24.4	29.3	31.6	34	
Maximum water flow	m³/h	30.7	34.6	41.9	45.9	50.7	50.7	63.2	69.5	77	77	77	
Water connections	≥	Male G 2 1/4"			Flange DN80				Flange DN100				
Maximum pressure (water side)	bar	ILD 10 bars / ILDC-ILDH 4 bars											
Air cooled condenser	Finned heat exchanger												
Fan ≥	mm	800											
Number x Motor rated power High Performance series - HP	nb x kW	2x1.7	2x1.7	2x1.8	2x1.7	2x1.7	2x1.7	4x2.24	4x2.24	4x2.24	4x2.24	4x2.24	
Number x Motor rated power Low Noise series - LN	nb x kW	2x1.2	2x1.2	2x1.2	2x1.1	2x1.1	2x1.1	4x1.48	4x1.48	4x1.48	4x1.48	4x1.48	
High Performance air flow - HP	m³/h	44000	42000	41000	44000	44000	44000	84300					
Low Noise air flow - LN - XLN	m³/h	32000	29000	30500	35000	35000	35000	63180					
Mini water content (ILD-ILDC)	l	220	213	357	164	207	203	213	212	213	290	364	
Water tank content model H	l	250						500					
Expansion vessel model C & H	l	18						34					
Standard pump	n°	④											
Height without mounts	mm	2117			2117				2080 (+205 XLN)				
Standard series length	mm	2190			2740				3698				
C series length	mm	2190			2740				3698				
H series length	mm	2190			2740				3698				
Depth	mm	2129			2129				2200				
Std range weight without charge	kg	1096	1195	1283	1570	1706	1878	2270	2320	2365	2445	2505	
C range weight without charge	kg	1194	1292	1355	1675	1804	1976	2550	2600	2645	2725	2825	
H range weight without charge	kg	1257	1356	1418	1748	1868	2040	2680	2730	2775	2855	2955	
Storage temperature	°C	+ 50°C											

① Capacities of HIGH PERFORMANCE series based on: EUROVENT conditions (EN 14511)

a/ COOLING : +12°C/+7°C and air inlet temp. at condenser +35°C
b/ HEATING: hot water outlet +45°C and outdoor air +7°C DB 86%RH

② EER and COP are gross values

③ Total sound power Lw, total sound pressure at 10 m from the unit, in free field, conformity with ISO 3744 norm

④ Depending on selection



ELECTRICAL SPECIFICATIONS



■ Standard units (pump not included)



		80V	90V	100V	120V	150V	180V	200V	240V	300V	350V
Electrical supply	ph/Hz/V	3~50Hz 400V (+6%/-10%) + Earth									
Control circuit voltage	ph/Hz/V	1~50Hz 230V (+6%/-10%) - transformer mounted									
Starting current without pump	A	95	111	118	135	198	130	143	149	230	256
Starting current SOFT START option	A	57	66	70	81	118	83	90	104	146	163
Circuit breaker (Neutral condition TN-TT)	kA	15			10		15			10	
Maxi wires section	mm ²	10			35			70			95
Maxi rated current ①	A	16.8	17.8	22.7	24.8	30.9	33.0	43.4	49.6	60.0	72.0

		400V	500V	540V	600V	700V	702V	800V	900V	1000V	1100V
Electrical supply	ph/Hz/V	3~50Hz 400V (+6%/-10%) + Earth									
Control circuit voltage	ph/Hz/V	1~50Hz 230V (+6%/-10%) - transformer mounted									
Starting current without pump	A	303	320	276	286	325	333	388	440	457	474
Starting current SOFT START option	A	191	209	192	202	237	243	279	317	333	350
Circuit breaker (Neutral condition TN-TT)	kA	10	35	10			50				
Maxi wires section	mm ²	95					150				
Maxi rated current ①	A	82.0	104.0	110.0	120.0	138	144	161	190	207	224

① Pump rated current not included

■ Hydraulic pumps (C and H models)

SINGLE PUMP														
	Pump type	n°	44	45	40	41	42	43	117	118	119	102	103	105
Mini flow	m ³ /h	1.0	1.9	5.0	6.0	7.0	8.0	15.0	15.0	15.0	20.0	20.0	20.0	20.0
Maxi pressure	mCE	20.6	20.9	17.5	21.5	22.0	24.5	15.5	26.0	39.0	14.5	18.0	26.0	33.0
Maxi flow	m ³ /h	8.0	13.0	19.0	22.5	30.0	30.0	50.0	50.0	50.0	70.0	86.0	74.0	74.0
Mini pressure	mCE	7.3	9.7	8.5	8.0	10.0	14.0	10.0	21.0	31.0	8.0	10.0	19.5	27.0
Main supply	V	3ph~50Hz 400V (+6%/-10%) + Earth												
Rated output	kW	0.55	0.75	0.75	1.1	1.5	1.85	2.2	4.0	7.5	3.0	4.0	5.5	7.5
Maxi rated current	A	1.7	2.1	1.85	2.67	3.9	4.61	4.5	7.8	13.8	6.3	8.0	10.3	13.8

TWIN PUMP												
	Pump type	n°	2 x 40	2 x 41	2 x 42	2 x 43	217	218	219	202	203	205
Mini flow	m ³ /h	5.0	6.0	7.0	8.0	15.0	15.0	15.0	20.0	20.0	20.0	20.0
Maxi pressure	mCE	17.5	21.5	22.0	24.5	15.5	26.0	39.0	14.5	18.0	26.0	33.0
Maxi flow	m ³ /h	19.0	22.5	30.0	30.0	50.0	50.0	50.0	70.0	86.0	74.0	74.0
Mini pressure	mCE	8.5	8.0	10.0	14.0	10.0	21.0	31.0	8.0	10.0	19.5	27.0
Main supply	V	3ph~50Hz 400V (+6%/-10%) + Earth										
Rated output	kW	0.75	1.1	1.5	1.85	2.2	4.0	7.5	3.0	4.0	5.5	7.5
Maxi rated current	A	1.85	2.67	3.9	4.61	4.5	7.8	13.8	6.3	8.0	10.3	13.8

HYDRAULIC FEATURES

Aquaciat 2 range, heat pumps or chillers for only cooling mode are available in 3 types:

- Ø standard machines **LD-ILD** without hydraulic equipment,
- Ø **LDC-ILC** models with single or twin water pump,
- Ø **LDH-ILH** hydraulic models equipped with single or twin water pump and water tank.

MODELS 80 - 300	"Standard" Version LD - ILD	"C" Version LDC - ILC	"H" Version LDH - ILDH
80 to 150			
180 to 300			























































































































































Water chillers

MODELS 350 - 1100	"Standard" Version LD - ILD	"C" Version LDC - ILDC	"H" Version LDH - ILDH
350 to 700			
	<p>With one or two single internal pumps (Nos. 40-43)</p>		<p>With one or two single internal pumps (Nos. 40-43)</p>
	<p>With one single external pump (Nos. 117-119)</p>	<p>With one single external pump (Nos. 117-119)</p>	<p>With one single external pump (Nos. 117-119)</p>
	<p>With one twin external pump (Nos. 217-219)</p>	<p>With one twin external pump (Nos. 217-219)</p>	<p>With one twin external pump (Nos. 217-219)</p>
702 to 1100			
	<p>With one single external pump (Nos. 102-119)</p>	<p>With one single external pump (Nos. 102-119)</p>	<p>With one single external pump (Nos. 102-119)</p>
	<p>With one twin external pump (Nos. 202-219)</p>	<p>With one twin external pump (Nos. 202-219)</p>	<p>With one twin external pump (Nos. 202-219)</p>

HYDRAULIC PUMP

Standard or Optional Mounting

The following water pumps concern the "C" or "H" series, equipped with a factory mounted hydraulic equipment.

	n°	80V	90V	100V	120V	150V	180V	200V	240V	300V	350V	400V	500V	540V	600V	700V	702V	800V	900V	1000V	1100V	
Single pumps	 44	Std	Std	Std	Std																	
	45					Std																
	 40						Std	Std	Std													
	41									Std												
	42																					
	43																					
	117																					
	118																					
	119																					
	 102																					
103																						
105																						
107																						
Twin pumps	 2X40						O	O	O													
	2X41									O												
	2X42																					
	2X43																					
	 217																					
	218																					
	218																					
	202																					
	203																					
	205																					
207																						

Std - Standard factory supply

O - Optional kit equipment for standard unit

 - Factory mounting on request

MAIN COMPONENTS

■ Casing

- casing with removable panels in galvanized sheet metal,
- enamelled paint colors RAL 7024 and RAL 7035

■ Hermetic SCROLL compressors

- Integrated motor cooled by suction gas
- Motor protection by a winding internal thermostat
- Mounting on antivibration mounts

■ Evaporator

- Brazed plate type exchanger(s)
- End plates and internal plates in AISI 316 stainless steel
- High performance optimized plates profile
- Thermal insulation

■ Condenser

- High performance air-cooled exchanger(s), with optimized profile aluminum fins and grooved copper tubes
- Cooling mode or heating mode exchanger on reversible heat pumps ILD-ILDC-ILDH series
- Propeller fan(s) with aluminium profiled blades
- 2 speed motor - IP55, Class F



Water chillers

Control functions or safety devices

- Water flow control
- Thermostatic expansion valve
- High and low refrigerant pressure safety devices
- Safety relief valves on refrigerant circuit
- Temperature sensors and pressure transducers
- Chilled water flow switch mounted
- Unit starting sequence,

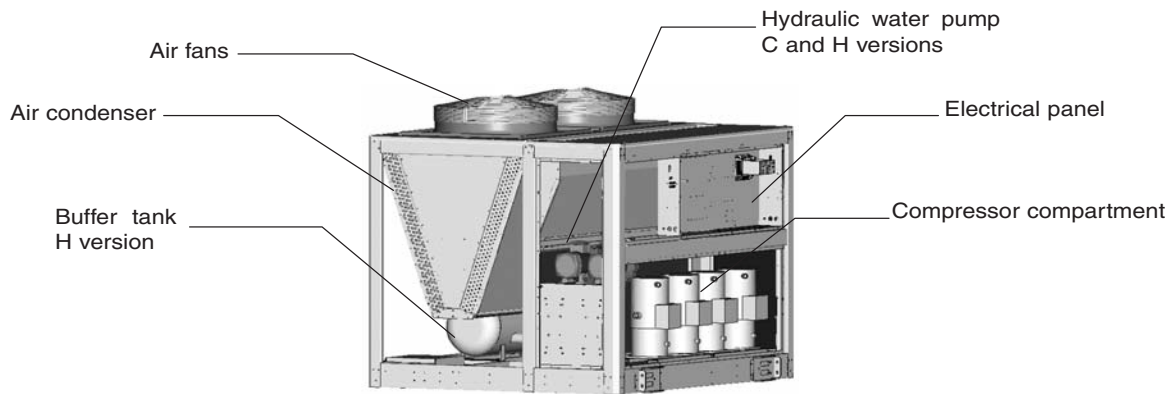

Electrical box

The electrical box is fully wired and contains all the electric components and the control process unit (CPU) board. It controls all the functions of the machine and allows operation monitoring, adjustment of the water temperature settings, or the interface with an external managing system.

The electrical box includes:

- Power and control circuit
- Wiring numbering
- Main safety circuit breaker on front panel with handle
- Control circuit transformer
- Protection circuit breakers on power and control circuits
- Compressor motor contactor(s)
- Main earthing
- Microprocessor electronic control system
- Free contacts for remote information or alarms.

ELECTRONIC CONTROL SYSTEM



Connect 2

CIAT microprocessor and CPU electronic control system with centralized controls and monitoring of internal operating status.

Includes:

- Run, Stop, Reset or Remote control functions,
- COOLING or HEATING mode selection switch,
- Output. RS485 output for BMS control (ModBus-JBus),
 - . Additional voltage free output adapter board ,
 - . Adapter for remote control (optional).
- Analogical multi-language LCD screen and LED indicators,

Functions:

- Monitoring of operation information by:

- . direct display of messages in different languages
- . direct display of temperatures and pressures
- Global compressors control with starting sequence, counting and equalization of compressors running times
- Auto-adaptive and advanced functions with a control system adjustment on the parameters drift
- Capacity stage control system on multi compressors as a function of the cooling or heating requirements on the water temperatures
- Control of the internal operating parameters
- Second setting point control
- Direct display of water temperatures and pressures
- Diagnosis of operating status and faults:
 - HP/LP, water flow, compressor motor(s), anti-frost
- Anti-short cycle protection
- Remote management and remote control
- Master/slave control of two units on the same water loop with alternation of the master unit and the slave unit based on the running times.
- Setpoint adjustable via a 4-20 mA signal
- Weekly schedules

OPTIONAL EQUIPMENT (KIT FOR ON-SITE MOUNTING)

Main options

- Additional potential free contact boards,
- Remote control box,
- Phase control = rotation direction, phase absence, under and over voltage (factory mounted size 350 to 1100),
- SOFT START (factory mounted size 350 to 1100),
- Anti-freeze protection,
- Fan speed control (factory mounted for 350 to 1100 sizes),
- Water filter 800 microns as standard equipment on LD-LDC-LDH or ILDC-ILDH, and optional accessory on LD-ILD,
- Evaporator and condenser flexible connections,
- Water adjustment kit including pressure gauge manifold, control valve and stop valve,
- Twin pump on sizes 180 to 1100 (factory mounted for 350 to 1100 models).
- 15 kW extra heater kit (ILD, ILDC, ILDH 80 to 150)
- Extra heater MODULE kit 15-30-45-60 kW (ILD, ILDC, ILDH 180 to 300)
- MULTICONNECT management up to 8 units.
- Management 4 extra heater
- LONWORKS protocol (gateway)
- Handling for container (350 to 1100)

SEASONAL PERFORMANCE

Most central air-conditioning systems used in the service industry in Europe use water chillers to produce cold.

Until recently, the efficiency of air conditioners in Europe was measured using a single nominal test point under full load, called Energy Efficiency Ratio (EER). However, a unit's efficiency depends on its operating conditions.

Analyses of installed systems show that heat load varies from season to season and that a water chiller operates primarily at reduced capacity.

The European Seasonal Energy Efficiency Ratio (ESEER) measures the seasonal efficiency of water chillers by taking into account their efficiency under partial load using formulas created by the **European certification body Eurovent**.

Seasonal heat load variations

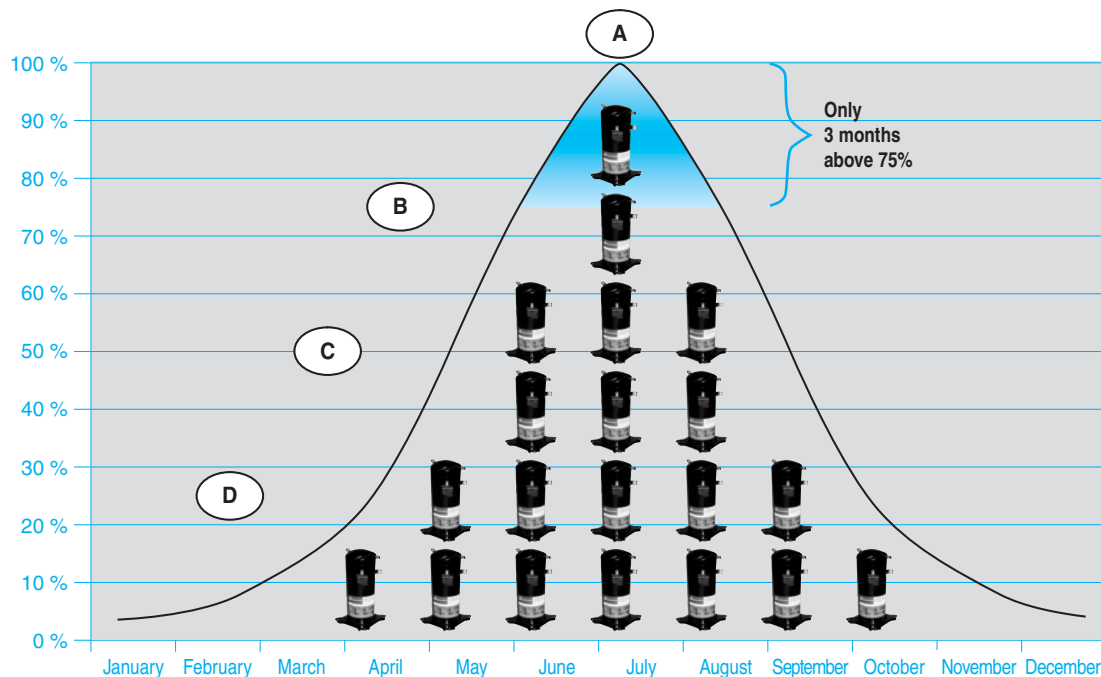

$$\text{ESEER} = A \times \text{EER}100\% + B \times \text{EER}75\% + C \times \text{EER}50\% + D \times \text{EER}25\%$$

A, B, C and D are weighting factors pertaining to a unit's running time based on its load

The ESEER design conditions for air-cooled water chillers are as follows:

Unit load	Air inlet temperature	Chilled water mode	Weighting factor
100 %	35 °C	12°C / 7°C	A= 0.03
75 %	30 °C	10.8°C / 7°C (*)	B = 0.33
50 %	25 °C	9.5°C / 7°C (*)	C = 0.41
25 %	20 °C	8.3°C / 7°C (*)	D = 0.23

(*) Water flow rate = Water flow rate at 100%

The efficiency under partial load is therefore essential when choosing a water chiller.

It is with this in mind that the new AQUACIAT2 range was designed. In particular, the entire range uses R410A refrigerant which, thanks to its extremely high thermodynamic performance, makes it possible to obtain much higher EER and ESEER ratings than with R407C and as much as 25% less electricity consumption.

As its compressors are connected in parallel on the refrigeration circuit, AQUACIAT2 easily and efficiently adjusts the cooling capacity to system's needs. The self-adjusting CONNECT control anticipates variations in load and turns on only the number of compressors needed. The compressors operate at optimum performance, energy efficiency is extremely high all year-round and, as a result, the system remains energy efficient for most of its life.



Water chillers

OPERATING RANGE (IN FULL LOAD)

LD - LDC - LDH 80V to 1100V

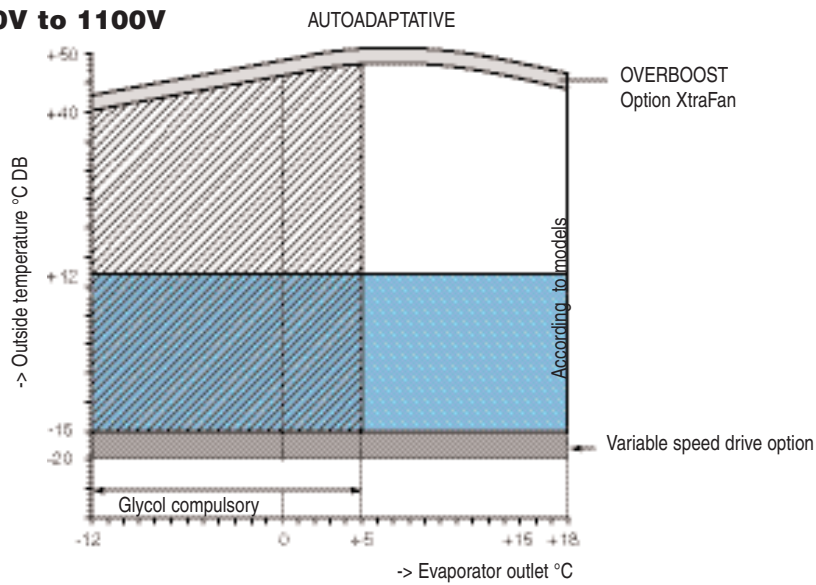

ILD - ILDC - ILDH 80V

COOLING mode operation

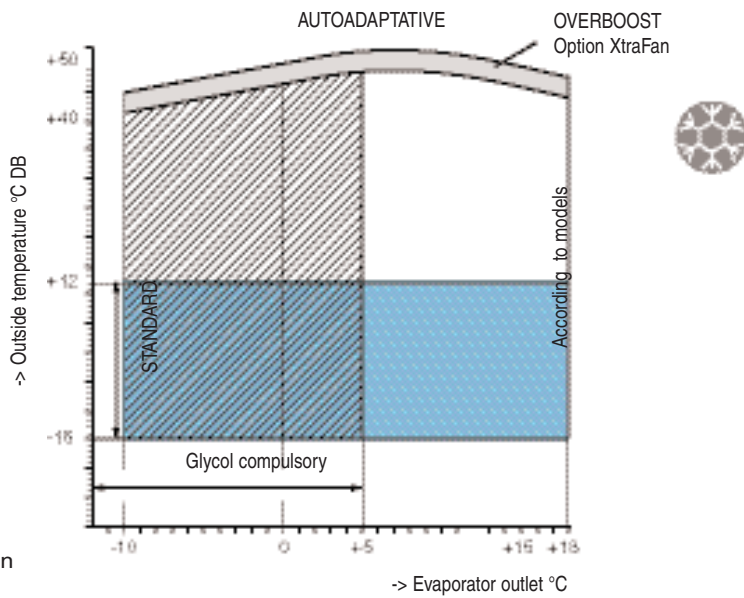

HEATING mode operation

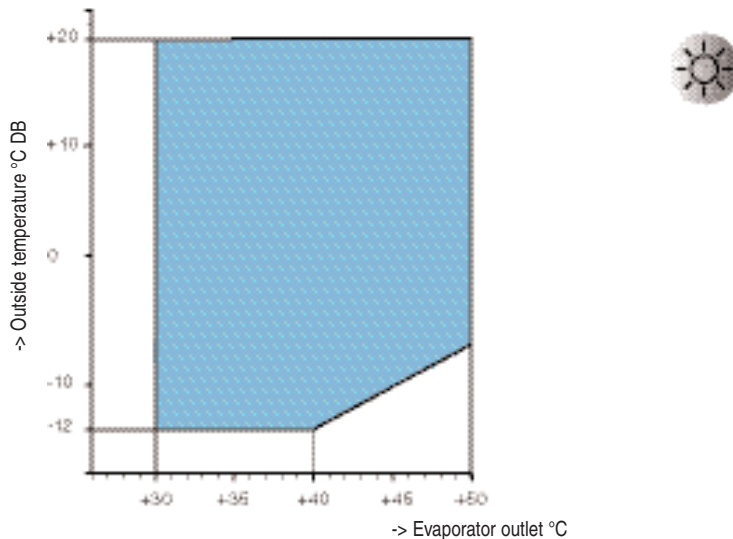

EVAPORATOR LIMITS

The curves show the minimum and maximum allowable temperature difference of chilled or glycol water depending on the outlet temperature.

Example:

For a water outlet: + 5 °C

Mini difference: 2,6 °C Water temp.: 7,6 / 5 °C

Max. difference: 6 °C Water temp.: 11 / 5 °C

For temperature differences not included between the 2 curves, consult us.

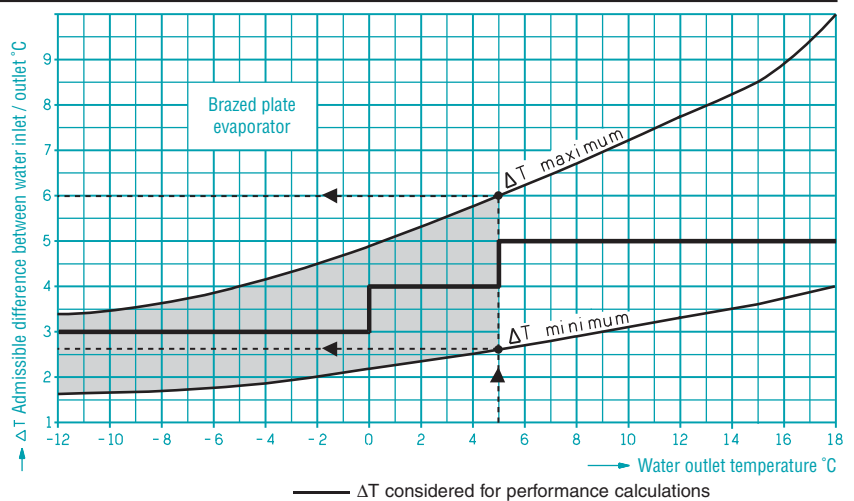

GLYCOL WATER COEFFICIENTS

■ 30 % concentration in glycol weight (MEG)

■ Freezing point of the solution: - 17.5 °C

K: Correction coefficient

values written in the brochure:

Pf: cooling capacity as per selection tables

Pa: compressors power input as per selection tables

ΔP: water pressure drop as per curves, for the corresponding corrected flow value (Qc)

values corrected as per above calculations:

Pfc: corrected cooling capacity

Qc: corrected flow, chilled or hot water

ΔPc: corrected water pressure drop, evaporator or condenser

CORRECTION		Positive conditions		Negative conditions	
		K	Calculation mode	K	Calculation mode
Evaporator	Colling capacity	0,98	$P_{fc} = P_f \times 0,98$	1,00	See selection table
	Chilled water flow	1,05	$Q_c = \frac{P_{cf} \times 0,86}{\Delta T} \times 1,05$	1,10	$Q_c = \frac{P_{cf} \times 0,86}{\Delta T} \times 1,10$
	Water pressure drop	1,15	$\Delta P_c = \Delta P \times 1,15$	1,30	$\Delta P_c = \Delta P \times 1,30$
	average working conditions	12 / 7 °C		See operating limits	
Condenser	Colling capacity	0,97	$P_{fc} = P_f \times 0,97$		
	Hot water flow	1,05	$Q_c = \frac{(P_{cf} + P_a) \times 0,86}{\Delta T} \times 1,05$		
	Water pressure drop	1,10	$\Delta P_c = \Delta P \times 1,10$		
	average working conditions	35 / 40 °C			
Evaporator + condenser	Colling capacity	0,95	$P_{fc} = P_f \times 0,95$	0,97	$P_{fc} = P_f \times 0,97$
	Chilled water flow	1,05	$Q_c = \frac{P_{cf} \times 0,86}{\Delta T} \times 1,05$	1,10	$Q_c = \frac{P_{cf} \times 0,86}{\Delta T} \times 1,10$
	Pressure drop at evaporator	1,15	$\Delta P_c = \Delta P \times 1,15$	1,30	$\Delta P_c = \Delta P \times 1,30$
	Hot water flow	1,05	$Q_c = \frac{(P_{cf} + P_a) \times 0,86}{\Delta T} \times 1,05$	1,05	$Q_c = \frac{(P_{cf} + P_a) \times 0,86}{\Delta T} \times 1,05$
	Water pressure drop at condenser	1,10	$\Delta P_c = \Delta P \times 1,10$	1,10	$\Delta P_c = \Delta P \times 1,10$

MINIMUM WATER VOLUME (COOLING MODE)

The Connect controller is equipped with an anticipation logic allowing high flexibility in adjusting the set points according to the parameters drifting, in particular for low water volume hydraulic installations.

An adapted management of the compressors operating periods avoids therefore the start of anti-short cycle functions, and in most cases, the requirement of a buffer tank

Series	80V	90V	100V	120V	150V	180V	200V	240V	300V	350V	400V	500V	540V	600V	700V	702V	800V	900V	1000V	1100V
Minimum installation volume (litres)	114	130	155	173	229	131	149	173	209	220	213	357	164	207	203	212	213	212	290	364

Comments: Industrial processes which require a high stability of water temperatures or installations with high thermal load variation can benefit from the installation of a water buffer tank.

With heat pump models, the hot water buffer tank volume must include the decrease of the water temperature due to the defrost period.



SOUND LEVELS

The **AQUACIAT 2** range design integrates the "noiseless" assembly technology for attenuation of vibrations and sound power sources:

- Scroll compressor(s) located away from the air flow
- Scroll compressor(s) mounted on antivibration mounts
- Piping dissociated from the unit structure
- Low speed fan(s)
- Automatic air flow adjustment
- Resilient mounts to be positioned between the ground and the unit as standard equipment

HIGH PERFORMANCES - HP

■ Sound power levels ref 2×10^{-12} Pa ± 3 dB

AQUACIAT	SOUND POWER LEVEL SPECTRUM (dB)														Lw global level dB(A)	
	125 Hz		250 Hz		500 Hz		1000 Hz		2000 Hz		4000 Hz		8000 Hz			
	LD	ILD	LD	ILD	LD	ILD	LD	ILD	LD	ILD	LD	ILD	LD	ILD	LD	ILD
80	78		73		72		72		65		60		54		75	
90	78		73		72		72		65		60		54		75	
100	80		79		76		76		70		64		57		79	
120	80		79		76		76		70		64		57		79	
150	79		81		79		76		69		62		56		80	
180	83		83		78		77		70		66		63		81	
200	81		80		78		77		70		64		60		81	
240	88		88		81		82		76		70		65		86	
300	84		90		85		85		79		72		66		89	
350	83		85		87		85		82		75		68		89	
400	83		85		87		86		82		76		69		90	
500	89		86		86		87		83		77		73		90	
540	84		87		88		86		83		76		70		90	
600	84		87		89		87		83		76		70		91	
700	84		87		89		87		83		76		70		91	
702	88	90	89	93	86	90	86	88	80	81	74	73	69	68	89	92
800	88	90	89	93	86	90	86	88	81	81	75	74	69	68	90	92
900	88	90	89	93	86	90	86	88	80	80	75	74	69	68	90	92
1000	88	90	89	93	86	90	86	88	80	81	75	74	69	68	90	92
1100	88	90	89	93	86	90	86	88	81	81	75	74	69	68	90	92

■ Sound pressure levels ref 2×10^{-5} Pa ± 3 dB

Measuring conditions: in free field, 10 metres from the unit, 1.50 metres from the ground, directivity 2

AQUACIAT	SOUND PRESSURE LEVEL SPECTRUM (dB)														Lp global level dB(A)	
	125 Hz		250 Hz		500 Hz		1000 Hz		2000 Hz		4000 Hz		8000 Hz			
	LD	ILD	LD	ILD	LD	ILD	LD	ILD	LD	ILD	LD	ILD	LD	ILD	LD	ILD
80	46		41		40		40		33		28		22		43	
90	46		41		40		40		33		28		22		43	
100	48		47		44		44		38		32		25		47	
120	48		47		44		44		38		32		25		47	
150	47		49		47		44		37		30		24		48	
180	51		51		46		45		38		34		31		49	
200	49		48		46		45		38		32		28		49	
240	56		56		49		50		44		38		33		54	
300	52		58		53		53		47		40		34		57	
350	51		53		55		53		50		43		36		57	
400	51		53		55		54		50		44		37		58	
500	57		54		54		55		51		45		41		58	
540	52		55		56		54		51		44		38		58	
600	52		55		57		55		51		44		38		59	
700	52		55		57		55		51		44		38		59	
702	56	58	57	61	54	58	54	56	48	49	42	41	37	36	57	60
800	56	58	57	61	54	58	54	56	49	49	43	42	37	36	58	60
900	56	58	57	61	54	58	54	56	48	49	43	42	37	36	58	60
1000	56	58	57	61	54	58	54	56	48	49	43	42	37	36	58	60
1100	56	58	57	61	54	58	54	56	49	49	43	42	37	36	58	60

NOTE: Acoustic pressure levels depend on the installation conditions and consequently are only given as an indication.

Only the sound power levels are comparable and certified.

Compliance with ISO 3744 standard $L_p = L_w - 10 \log S$



LOW NOISE - LN

■ Sound power levels ref 2×10^{-12} Pa ± 3 dB

AQUACIAT	SOUND POWER LEVEL SPECTRUM (dB)														Lw global level dB(A)	
	125 Hz		250 Hz		500 Hz		1000 Hz		2000 Hz		4000 Hz		8000 Hz			
	LD	ILD	LD	ILD	LD	ILD	LD	ILD	LD	ILD	LD	ILD	LD	ILD	LD	ILD
80	78		70		68		66		61		55		50		71	
90	78		70		68		66		61		55		50		71	
100	78		74		73		71		66		61		54		75	
120	77		75		73		71		66		61		54		75	
150	82		77		76		71		67		59		53		77	
180	82		82		76		73		66		64		62		79	
200	81		79		77		73		67		65		62		78	
240	87		87		77		75		68		65		63		82	
300	82		87		80		78		72		64		58		83	
350	76		81		81		78		74		68		62		83	
400	76		81		81		79		75		70		65		83	
500	85		83		84		80		76		71		66		85	
540	78		84		84		81		76		71		67		85	
600	77		83		85		80		75		69		65		85	
700	77		83		85		80		75		69		65		85	
702	85	88	83	87	81	85	79	82	76	76	68	68	61	62	84	87
800	85	88	83	87	81	85	81	83	78	77	70	70	62	62	85	87
900	86	88	83	87	81	85	79	82	76	75	71	70	63	63	84	87
1000	86	88	83	87	81	85	80	82	77	76	71	70	63	63	84	87
1100	86	88	83	87	81	85	81	83	78	77	73	71	63	63	85	87
702 XLN*	78		78		78		76		74		67		59		81	
800 XLN*	78		78		78		78		75		69		60		82	
900 XLN*	79		78		78		77		73		69		61		81	
1000 XLN*	79		78		77		77		74		69		61		81	
1100 XLN*	78		78		77		79		76		71		61		83	

* Xtra LOW NOISE model option

■ Sound pressure levels ref 2×10^{-5} Pa ± 3 dB

Measuring conditions:

- . in free field
- . 10 meters from the unit, 1.50 meters from the ground
- . directivity 2

AQUACIAT	SOUND PRESSURE LEVEL SPECTRUM (dB)														Lp global level dB(A)	
	125 Hz		250 Hz		500 Hz		1000 Hz		2000 Hz		4000 Hz		8000 Hz			
	LD	ILD	LD	ILD	LD	ILD	LD	ILD	LD	ILD	LD	ILD	LD	ILD	LD	ILD
80	46		38		36		34		29		23		18		39	
90	46		38		36		34		29		23		18		39	
100	46		42		41		39		34		29		22		43	
120	45		43		41		39		34		29		22		43	
150	50		45		44		39		35		27		21		45	
180	50		50		44		41		34		32		30		47	
200	49		47		45		41		35		33		30		46	
240	55		55		45		43		36		33		31		50	
300	50		55		48		46		40		32		26		51	
350	44		49		49		46		42		36		30		51	
400	44		49		49		47		43		38		33		51	
500	53		51		52		48		44		39		34		53	
540	46		52		52		49		44		39		35		53	
600	45		51		53		48		43		37		33		53	
700	45		51		53		48		43		37		33		53	
702	53	56	51	55	49	53	47	50	44	44	36	36	29	30	52	55
800	53	56	51	55	49	53	49	51	46	45	38	38	30	30	53	55
900	54	56	51	55	49	53	47	50	44	43	39	38	31	31	52	55
1000	54	56	51	55	49	53	48	50	45	44	39	38	31	31	52	55
1100	54	56	51	55	49	53	49	51	46	45	41	39	31	31	53	55
702 XLN*	46		46		46		44		42		35		27		49	
800 XLN*	46		46		46		46		43		37		28		50	
900 XLN*	47		46		46		45		41		37		29		49	
1000 XLN*	47		46		45		45		42		37		29		49	
1100 XLN*	46		46		45		47		44		39		29		51	

* Xtra LOW NOISE model option

NOTE: Acoustic pressure levels depend on installation conditions, and consequently are only given as an indication.

Remember that only the sound power levels are comparable and certified.

Compliance with ISO 3744 standard $L_p = L_w - 10 \log S$



XTRAFAN FAN SYSTEM (OPTIONAL EQUIPMENT)

AquaCiat2 units 80V to 700V models, for chillers only LD-LDC-LDH series or reversible HEAT PUMPS ILD-ILDC-ILDH series, can be equipped with an XTRAFAN option.

In comparison with standard electric motors controlled by a traditional variator of frequency, this type of electric motor with electronic poles switching equipment and permanent magnet rotors, is characterized by excellent mechanical efficiency and a particularly low noise level, regardless of the load on the shaft.

Main description

The XTRAFAN option offers a broad range of functions allowing for particularly flexible installation conditions, notably:

- the possibility of being installed in a cramped space, for example on a terrace surrounded by walls, where only a discharge with a static pressure from 100 to 200 Pascals in a duct allows a use without recycling or mixing air to the condenser intake,
- the installation in a particularly noise-sensitive urban environment, where only a suitable sound trap adapted to the air discharge can allow operation,
- the guarantee of obtaining continued operation during temperature peaks in hot climates such as the Middle East, thanks to an "over-boost" function of the condenser fan speed,
- an auto-adjustable speed variation function allowing a highly protected "all season" operation in cooling mode for the industrial process including rigorous winter periods with an external temperature of -20°C,
- the possibility of precisely adjusting on site the fan speed "just enough" to obtain an optimal air discharge pressure, or a maximum noise level tolerated by the environment of the machine,
- an improvement in terms of the EER efficiency and the electrical consumption of the chiller in cooling mode, directly proportional to the refrigerating load requested by the installation.

Technical specifications and operating range

The XTRAFAN option allows the user to chose one of three possible operating functions of the machine:

- a fortified running of the chiller thanks to the "over boost" fan function in free discharge, in order to extend on full load the outside temperature range from +46 to +50°C,
- reaching an intermediate available static pressure of 100 to 125 Pa with the rated air flow, allowing a duct air discharge at the condenser outlet in order to avoid fan recycling phenomena,
- reaching a maximum static pressure from 130 to 200 Pa according to models at the air discharge with a low air flow, recommended for on-site installation of a sound trap on the air discharge.

	HIGH outside temperature Fan over boost			RATED Static pressure			MAXIMUM Static pressure		
	Available pressure Pa	Air flow m³/h	Operation limits °C	Available pressure Pa	Air flow m³/h	Operation limits °C	Available pressure Pa	Air flow m³/h	Operation limits °C
80V - 90V	0	16500	Operation limits widened to +46°C to +50°C	125	10400	Idem PERFORMANCE mode	160	9000	Idem LOW NOISE mode
100V - 120V		23800		150	17000		200	12000	
150V		23000		150	16200		200	12000	
180 - 200V		23500		150	16500		200	12000	
240V - 300V		26000		100	22100		200	17000	
350V - 400V		50400		100	42000		200	34000	
500V		52000		100	40000		200	34000	
540V - 600V		61200		100	48000		130	43000	
700V		58000		100	46000		130	43000	



Installation recommendations

The location on site of a machine equipped with the optional XTRAFAN system supposes some technical care particularly in case of an indoor installation.

For example, the evacuation of the condensates which is a specificity of reversible air to water heat pumps, including during a period of very low outside temperatures.

During defrosting periods, reversible heat pumps are likely to release a significant quantity of water on the ground that must be disposed of, as well as water vapor from the fan discharge which can damage an air duct.

The ground supporting the machine must be perfectly watertight and be able to collect and then drain defrosting water, including during freezing periods, and it is recommended to raise the chiller about 300 mm from the ground.

If a discharge air duct is mounted on site, the weight of the latter should under no circumstances be supported by the roof of the AquaCiat2, and it is recommended to mount an optional flexible air sleeve on the unit air discharge.

Sound levels XTRAFAN series

- Machine sound levels, direct air discharge without any air duct on fan motor (OVERBOOST)

Aquaciat 2	Direct air discharge (OVERBOOST) / SOUND POWER LEVEL SPECTRUM (dB)							Global level Lw dB(A)
	125 Hz	250 Hz	500 Hz	1000 Hz	2000 Hz	4000 Hz	8000 Hz	
80	76	74	75	74	73	71	65	80
90	72	74	74	73	73	72	66	79
100	75	75	75	77	76	74	67	82
120	74	79	76	77	76	75	67	82
150	84	87	80	77	75	71	66	84
180	72	77	77	77	75	75	68	82
200	78	77	77	78	77	77	69	84
240	82	85	82	81	80	79	71	87
300	90	93	82	81	80	78	70	89
350	83	80	85	84	83	81	72	89
400	83	80	85	84	83	81	73	89
500	83	80	85	85	83	81	74	90
540	73	79	83	77	75	76	72	84
600	74	81	85	78	75	76	72	85
700	83	81	82	79	78	78	74	86

- Sound levels of units, ducted fan(s) with a NOMINAL or MAXIMUM available pressure

Aquaciat 2	NOMINAL static pressure / SOUND POWER LEVEL SPECTRUM (dB)							Global level Lw dB(A)
	125 Hz	250 Hz	500 Hz	1000 Hz	2000 Hz	4000 Hz	8000 Hz	
80	85	82	81	81	76	73	68	85
90	85	82	81	81	76	74	69	85
100	77	76	76	78	76	74	68	83
120	76	80	77	78	76	75	68	83
150	84	87	80	78	76	72	68	84
180	75	78	78	78	76	75	69	83
200	79	78	77	79	78	77	70	84
240	84	85	81	80	79	80	74	87
300	91	93	82	80	79	79	73	88
350	85	83	85	83	82	82	76	89
400	85	83	85	83	82	82	76	89
500	85	82	84	83	83	83	76	90
540	77	82	84	79	76	75	72	85
600	78	83	85	79	77	74	72	86
700	84	84	83	81	80	77	74	87

Aquaciat 2	MAXIMUM static pressure / SOUND POWER LEVEL SPECTRUM (dB)							Global level Lw dB(A)
	125 Hz	250 Hz	500 Hz	1000 Hz	2000 Hz	4000 Hz	8000 Hz	
80	90	87	85	82	77	74	68	87
90	90	87	85	82	77	74	68	87
100	83	82	82	83	80	76	71	87
120	83	84	82	83	80	77	71	87
150	86	88	83	83	80	74	70	88
180	83	83	82	83	79	76	71	87
200	84	83	82	83	80	78	72	87
240	85	87	84	83	82	81	74	89
300	91	93	84	83	82	80	74	90
350	87	87	87	86	84	83	77	91
400	87	87	87	86	85	83	77	92
500	87	87	87	86	85	83	77	92
540	82	86	86	82	78	76	72	87
600	82	86	87	82	78	75	72	88
700	87	89	87	84	81	78	74	89





Water chillers

COOLING CAPACITIES

COOLING ONLY models

LD LDC LDH	Evaporator water outlet temperature °C	INLET AIR TEMPERATURE AT THE CONDENSER °C										
		25		30		35		40		46		
		Pf kW	Pa kW	Pf kW	Pa kW	Pf kW	Pa kW	Pf kW	Pa kW	Pf kW	Pa kW	
80V	Glycol water	-12	10,9	4,9	10,1	5,4	9,3	6,0	8,5	6,6		
		-10	11,8	4,9	11,0	5,4	10,2	6,0	9,3	6,7		
		-8	12,8	5,0	11,9	5,5	11,1	6,1	10,2	6,8		
		-4	14,9	5,1	13,9	5,7	13,0	6,2	12,0	6,9		
		0	17,1	5,3	16,1	5,8	15,1	6,4	14,0	7,1	12,6	8,0
	Pure water	5	20,8	5,5	19,6	6,1	18,4	6,7	17,1	7,4	15,5	8,2
		7	22,3	5,7	21,0	6,2	19,7	6,94	18,4	7,5	16,7	8,3
		12	25,8	5,9	24,4	6,5	22,9	7,1	21,4	7,8	19,5	8,6
15		28,1	6,1	26,6	6,7	25,0	7,3	23,4	8,0	21,4	8,8	
90V	Glycol water	-12	12,4	5,5	11,6	6,2	10,7	6,8	9,6	7,6		
		-10	13,5	5,6	12,7	6,2	11,7	6,9	10,6	7,7		
		-8	14,6	5,7	13,7	6,3	12,7	7,0	11,7	7,8		
		-4	16,9	5,9	15,9	6,5	14,9	7,2	13,8	8,0		
		0	19,5	6,1	18,4	6,7	17,3	7,4	16,1	8,2		
	Pure water	5	23,5	6,5	22,2	7,0	20,9	7,7	19,6	8,5	17,3	9,6
		7	25,1	6,6	23,8	7,2	22,4	8,06	21,0	8,6	18,6	9,8
		12	29,0	7,0	27,4	7,6	25,9	8,2	24,3	9,0	21,6	10,2
15		31,5	7,2	29,8	7,8	28,1	8,5	26,3	9,3	23,5	10,5	
100V	Glycol water	-12	14,8	6,4	13,8	7,1	12,8	7,9	11,7	8,7		
		-10	16,1	6,4	15,1	7,2	14,0	8,0	12,9	8,8		
		-8	17,4	6,5	16,3	7,3	15,2	8,1	14,0	8,9		
		-4	20,2	6,7	19,1	7,4	17,8	8,2	16,5	9,1		
		0	23,3	6,9	22,0	7,6	20,6	8,4	19,1	9,3	17,3	10,4
	Pure water	5	27,7	7,2	26,1	7,9	24,5	8,7	22,9	9,5	20,8	10,7
		7	29,5	7,3	28,0	8,0	26,3	8,98	24,6	9,7	22,4	10,8
		12	34,3	7,6	32,5	8,3	30,7	9,1	28,7	10,0	26,2	11,1
15		37,4	7,8	35,5	8,5	33,4	9,3	31,3	10,2	28,7	11,3	
120V	Glycol water	-12	16,6	7,7	15,5	8,4	14,4	9,2	13,1	10,2		
		-10	18,1	7,8	16,9	8,5	15,7	9,3	14,4	10,3		
		-8	19,6	7,9	18,3	8,6	17,0	9,5	15,7	10,4		
		-4	22,7	8,1	21,3	8,8	19,9	9,7	18,4	10,6		
		0	26,1	8,3	24,6	9,0	23,0	9,9	21,4	10,8	19,3	12,1
	Pure water	5	31,5	8,7	29,7	9,4	27,9	10,3	26,0	11,2	23,6	12,4
		7	33,7	8,8	31,8	9,6	29,9	10,6	27,9	11,4	25,4	12,6
		12	39,0	9,2	36,9	10,0	34,7	10,8	32,4	11,8	29,6	13,0
15		42,4	9,5	40,2	10,2	37,8	11,1	35,3	12,0	32,4	13,2	
150V	Glycol water	-12	21,8	9,5	20,6	10,4	19,4	11,2	18,0	12,2		
		-10	23,6	9,6	22,4	10,5	21,0	11,4	19,6	12,4		
		-8	25,4	9,8	24,2	10,7	22,8	11,7	21,2	12,7		
		-4	29,4	10,1	27,9	11,1	26,3	12,1	24,6	13,2		
		0	33,7	10,5	32,0	11,4	30,3	12,5	28,3	13,7	25,9	15,1
	Pure water	5	40,5	11,0	38,5	12,0	36,4	13,1	34,1	14,3	31,3	15,8
		7	43,5	11,2	41,2	12,3	38,9	13,7	36,5	14,6	33,6	16,1
		12	50,2	11,8	47,7	12,9	45,0	14,0	42,2	15,2	39,0	16,7
15		54,6	12,2	51,8	13,3	48,9	14,4	45,9	15,7	42,5	17,2	
180V	Glycol water	-12	25,4	10,5	23,9	11,7	22,0	12,9	20,0	14,4		
		-10	27,6	10,7	26,0	11,8	24,1	13,0	22,1	14,5		
		-8	29,8	10,8	28,2	11,9	26,3	13,2	24,3	14,6		
		-4	34,6	11,0	32,9	12,2	30,9	13,4	28,7	14,9		
		0	40,0	11,3	38,0	12,5	35,8	13,7	33,4	15,2	30,1	17,3
	Pure water	5	48,4	11,8	46,1	13,0	43,5	14,3	40,8	15,7	37,4	17,6
		7	52,0	12,1	49,4	13,2	46,7	14,8	43,8	15,9	40,2	17,9
		12	60,4	12,7	57,3	13,9	54,2	15,2	51,0	16,6	47,0	18,5
15		65,6	13,2	62,3	14,4	58,9	15,6	55,5	17,0	51,2	18,9	

Pf: Cooling capacity valid for delta T according to operating limits
 Pa: Power input
 Pc: Heating capacity valid for delta T according to operating limits

 Mandatory glycol water utilization zone
 Calculation fouling factor 0,00005 m² °C/W
 EUROVENT conditions (EN 14511)

AQUACIAT 2

R410A

HIGH PERFORMANCES - HP



COOLING CAPACITIES



COOLING ONLY models

LD LDC LDH	Evaporator water outlet temperature °C	INLET AIR TEMPERATURE AT THE CONDENSER °C										
		25		30		35		40		46		
		Pf kW	Pa kW	Pf kW	Pa kW	Pf kW	Pa kW	Pf kW	Pa kW	Pf kW	Pa kW	
200V	Glycol water	-12	28,9	12,3	27,1	13,8	25,3	15,3	23,0	17,0		
		-10	31,9	12,6	29,7	14,0	27,6	15,5	25,3	17,2		
		-8	34,5	12,8	32,3	14,2	30,0	15,8	27,7	17,5		
		-4	40,0	13,2	37,7	14,6	35,2	16,2	32,6	17,9		
		0	46,2	13,6	43,6	15,1	40,8	16,6	37,9	18,4	34,2	20,7
	Pure water	5	55,7	14,3	52,7	15,8	49,4	17,4	46,0	19,1	41,9	21,4
		7	59,7	14,6	56,5	16,1	53,1	18,1	49,5	19,4	45,1	21,7
		12	69,2	15,4	65,4	16,8	61,6	18,5	57,6	20,2	52,8	22,4
		15	75,2	15,9	71,1	17,4	67,0	19,0	62,7	20,7	57,5	22,9
		240V	Glycol water	-12	33,6	15,0	31,4	16,4	29,0	18,0	26,6	19,8
-10	36,6			15,1	34,2	16,6	31,7	18,2	29,2	20,0		
-8	39,5			15,3	36,9	16,8	34,5	18,4	31,8	20,2		
-4	45,8			15,6	43,2	17,1	40,3	18,8	37,5	20,7		
0	52,5			16,0	49,9	17,5	46,7	19,2	43,4	21,0	39,4	23,5
Pure water	5		63,7	16,6	60,4	18,2	56,8	19,9	53,0	21,7	48,4	24,2
	7		68,3	16,9	64,9	18,5	61,0	20,5	56,9	22,0	52,0	24,4
	12		79,2	17,6	75,3	19,2	70,9	20,8	66,4	22,7	60,8	25,1
	15		86,4	18,1	81,9	19,6	77,3	21,3	72,4	23,1	66,4	25,5
	300V		Glycol water	-12	42,6	19,0	40,7	20,7	38,5	22,5	35,4	24,5
-10		46,6		19,3	44,3	21,1	41,6	23,0	38,8	25,0		
-8		50,2		19,7	47,7	21,6	45,0	23,5	42,0	25,5		
-4		58,4		20,4	55,3	22,3	52,1	24,4	48,8	26,5		
0		66,7		21,1	63,5	23,1	59,8	25,3	56,0	27,5	51,3	30,3
Pure water		5	80,4	22,2	76,2	24,3	71,9	26,6	67,4	28,9	61,7	32,0
		7	85,8	22,7	81,6	24,8	76,8	27,7	72,3	29,4	66,4	32,5
		12	99,2	24,0	94,1	26,1	88,8	28,4	83,4	30,8	77,0	33,8
		15	107,7	24,8	102,1	26,9	96,4	29,2	90,6	31,6	83,9	34,6
		350V	Glycol water	-12	48,6	22,5	46,2	24,4	43,4	26,5	40,3	28,9
-10	53,2			22,8	50,4	24,7	47,5	26,9	44,4	29,3		
-8	57,8			23,1	54,8	25,0	51,6	27,3	48,4	29,7		
-4	67,9			23,7	64,3	25,7	60,7	28,0	56,9	30,5	52,1	33,9
0	78,7			24,3	74,9	26,4	70,5	28,7	66,2	31,4	60,8	34,8
Pure water	5		96,1	25,4	91,1	27,5	86,0	29,9	80,8	32,6	74,3	36,1
	7		103,3	25,8	98,1	28,0	92,6	31,0	87,0	33,1	80,1	36,7
	12		120,7	27,0	114,5	29,2	108,2	31,7	101,6	34,4	93,9	38,0
	15		132,1	27,8	125,1	30,0	118,2	32,5	111,2	35,3	102,7	38,9
	18		143,7	28,7	136,2	30,9	128,8	33,4	121,2	36,2	112,3	39,9
400V	Glycol water	-12	54,4	25,7	51,3	27,9	48,1	30,4	44,3	33,0		
		-10	59,3	26,0	56,2	28,4	52,7	30,9	48,9	33,6		
		-8	64,5	26,4	61,1	28,8	57,5	31,4	53,6	34,1		
		-4	75,6	27,2	71,7	29,7	67,6	32,3	63,3	35,2		
		0	87,5	28,0	83,1	30,6	78,5	33,3	73,5	36,3	67,1	40,0
	Pure water	5	106,0	29,3	101,1	32,0	95,4	34,8	89,7	37,8	82,1	41,7
		7	114,3	30,0	108,5	32,5	102,6	36,3	96,3	38,5	88,5	42,4
		12	133,0	31,4	126,5	34,0	119,4	36,9	112,3	40,0	103,2	43,9
		15	145,1	32,4	137,9	35,0	130,2	37,8	122,3	40,9	112,7	44,8
		18	158,0	33,4	149,8	36,0	141,6	38,8	133,0	41,9	122,8	45,8
500V	Glycol water	-12	67,0	31,8	62,9	34,7	58,6	37,8	53,6	41,2		
		-10	73,0	32,3	68,8	35,3	64,3	38,5	59,2	41,9		
		-8	79,3	32,8	74,9	35,9	70,1	39,2	64,9	42,7		
		-4	92,9	34,1	87,8	37,2	82,4	40,5	76,6	44,2		
		0	107,1	35,4	101,5	38,6	95,4	42,0	89,0	45,7	80,6	50,5
	Pure water	5	128,4	37,4	122,7	40,7	115,5	44,3	107,8	48,1	98,4	52,9
		7	138,9	38,3	131,5	41,7	123,9	46,3	115,7	49,1	105,7	53,9
		12	160,8	40,5	152,3	43,9	143,2	47,5	134,0	51,3	123,0	56,0
		15	174,9	42,0	165,4	45,3	155,6	49,0	145,7	52,7	133,9	57,4
		18	189,3	43,4	179,1	46,8	168,3	50,4	157,8	54,2	145,3	58,7
540V	Glycol water	-12	75,8	34,3	71,3	37,5	66,6	40,9	61,2	44,7		
		-10	82,2	34,8	77,5	38,1	72,3	41,6	66,9	45,4		
		-8	88,7	35,3	83,7	38,6	78,4	42,3	72,8	46,2		
		-4	102,8	36,3	97,2	39,8	91,2	43,6	85,0	47,6		
		0	117,9	37,4	111,8	41,0	105,0	44,9	98,0	49,0	89,3	54,4
	Pure water	5	142,2	39,2	134,9	42,9	126,9	46,8	118,6	51,1	108,5	56,5
		7	152,3	40,0	144,4	43,7	135,9	48,6	127,3	51,9	116,6	57,4
		12	176,3	41,8	167,1	45,5	157,5	49,6	147,6	53,9	135,8	59,3
		15	191,6	43,1	181,7	46,8	171,2	50,8	160,7	55,1	148,2	60,5

Pf: Cooling capacity valid for delta T according to operating limits
 Pa: Power input
 Pc: Heating capacity valid for delta T according to operating limits

Light blue box: Mandatory glycol water utilization zone
 Dark blue box: Calculation fouling factor 0,00005 m² °C/W
 Blue box: EUROVENT conditions (EN 14511)



Water chillers

COOLING CAPACITIES



COOLING ONLY models

LD LDC LDH	Evaporator water outlet temperature °C	INLET AIR TEMPERATURE AT THE CONDENSER °C										
		25		30		35		40		46		
		Pf kW	Pa kW	Pf kW	Pa kW	Pf kW	Pa kW	Pf kW	Pa kW	Pf kW	Pa kW	
600V	Glycol water	-12	84,9	38,3	80,4	41,7	75,5	45,4	69,6	49,2		
		-10	92,0	39,1	87,0	42,6	81,9	46,4	75,9	50,4		
		-8	98,9	39,7	94,0	43,4	88,4	47,3	82,5	51,4		
		-4	114,5	41,1	108,7	45,0	102,4	49,2	95,7	53,5		
	0	131,2	42,5	124,7	46,6	117,5	51,0	110,0	55,5			
	Pure water	5	157,8	44,8	149,7	49,0	141,3	53,6	132,4	58,3	117,6	65,2
		7	169,1	45,8	160,3	50,1	151,1	55,7	141,8	59,4	126,1	66,5
		12	195,2	48,1	185,1	52,5	174,7	57,1	163,9	61,9	146,1	69,4
		15	211,9	49,7	201,0	54,0	189,6	58,6	178,1	63,6	158,5	69,5
		18	229,5	51,5	217,6	55,7	205,2	60,3	193,2	65,2	164,7	71,0
700V		Glycol water	-12	93,6	43,2	88,9	47,3					
	-10		102,0	44,0	96,6	48,0	90,7	52,5				
	-8		110,5	44,7	104,8	48,8	98,7	53,3				
	-4		128,7	46,2	122,4	50,5	115,0	55,2	107,6	60,4		
	0	148,7	47,8	141,3	52,2	132,8	57,0	124,1	62,3	113,7	69,2	
	Pure water	5	182,0	50,7	172,6	55,2	162,8	60,2	152,7	65,6	140,8	72,6
		7	193,9	51,7	183,8	56,3	173,3	64,3	162,7	66,7	150,1	73,7
		12	225,1	54,6	213,5	59,3	201,3	65,3	189,3	69,8	175,4	76,9
		15	244,9	56,5	232,3	61,2	219,3	66,4	206,5	71,9	192,0	78,9
		18	265,9	58,7	252,2	63,4	238,2	68,5	224,6	74,0	209,5	81,1
702V		Glycol water	-12	97,9	44,0	92,6	47,9	87,1	52,3	80,7	57,4	
	-10		107,6	44,3	102,0	48,2	95,9	52,6	89,4	57,6		
	-8		117,5	44,6	111,5	48,5	105,2	52,9	98,4	58,0	89,0	64,9
	-4		137,8	45,7	131,1	49,7	123,8	54,2	116,2	59,2	106,5	66,0
	0	161,3	47,0	153,1	51,1	144,9	55,7	136,1	60,8	125,3	67,7	
	Pure water	5	196,9	49,0	187,5	53,2	177,3	58,0	166,9	63,3	153,9	70,4
		7	210,5	49,9	200,2	54,1	189,3	60,2	178,1	64,2	164,3	71,3
		12	245,9	52,1	234,2	56,5	221,3	61,3	208,4	66,7	192,6	73,9
		15	269,2	53,8	256,0	58,1	242,0	63,0	227,9	68,4	211,0	75,6
		18	293,3	55,5	278,7	59,9	263,8	64,8	248,5	70,2	230,5	77,5
800V		Glycol water	-12	108,4	49,7	104,0	54,3	97,3	59,2	89,5	64,8	
	-10		120,6	50,2	114,2	54,8	107,4	59,8	99,9	65,4		
	-8		131,1	50,8	124,2	55,6	117,3	60,6	109,5	66,2	98,3	73,4
	-4		153,4	52,3	146,1	57,2	138,0	62,5	129,3	68,2	117,9	75,6
	0	178,6	54,0	170,4	59,0	161,2	64,4	151,5	70,3	138,9	77,9	
	Pure water	5	218,0	56,6	208,0	61,7	196,9	67,3	185,2	73,4	170,2	81,2
		7	232,8	57,7	221,8	62,8	209,9	69,8	197,5	74,5	181,7	82,3
		12	271,4	60,5	258,3	65,6	244,6	71,2	230,2	77,4	212,2	85,3
		15	296,5	62,5	281,8	67,5	267,0	73,2	251,1	79,3	231,9	87,2
		18	322,5	64,5	306,7	69,6	290,2	75,2	273,2	81,3	252,7	89,2
900V		Glycol water	-12	132,8	57,9	126,0	63,6	118,9	69,9	111,2	76,7	
	-10		144,9	58,4	137,9	64,1	130,3	70,3	122,3	77,3		
	-8		157,5	59,2	149,6	64,9	141,6	71,2	133,1	78,1		
	-4		184,0	60,9	175,0	66,6	165,6	73,0	155,7	79,9	143,5	89,2
	0	214,7	62,9	203,9	68,6	192,9	75,0	181,6	82,1	167,4	91,4	
	Pure water	5	261,6	66,1	249,0	72,0	235,3	78,4	221,5	85,5	204,3	94,9
		7	278,9	67,3	265,5	73,2	250,9	81,5	236,3	86,9	218,0	96,2
		12	325,4	70,8	309,3	76,8	292,5	83,3	275,4	90,6	254,3	100,0
		15	355,7	73,2	337,8	79,2	319,3	85,8	300,3	93,0	277,8	102,3
		18	386,7	75,8	367,4	81,9	347,2	88,5	326,3	95,9	302,2	105,0
1000V		Glycol water	-12	141,5	63,1	134,4	69,3	126,9	76,3	118,6	84,4	
	-10		155,0	64,0	147,1	70,1	138,8	77,0	130,3	84,9		
	-8		169,0	64,9	160,2	71,1	151,4	78,0	142,1	85,8		
	-4		198,1	67,0	188,3	73,1	177,8	80,0	166,9	87,8	153,7	98,3
	0	230,4	69,7	219,5	75,6	207,7	82,4	195,3	90,0	179,6	100,6	
	Pure water	5	281,5	73,6	268,2	79,8	253,8	86,6	238,8	94,3	219,9	104,8
		7	300,8	75,1	286,0	81,3	270,6	89,7	254,5	95,9	234,6	106,4
		12	350,7	78,8	333,4	85,3	315,2	92,4	296,5	100,2	273,7	110,7
		15	383,1	81,3	363,6	87,9	343,6	95,1	323,4	103,0	298,9	113,4
		18	416,5	83,9	395,2	90,6	373,4	97,9	351,6	105,8	325,3	116,2
1100V		Glycol water	-12	154,1	69,4	145,9	76,3	137,1	83,9	127,7	92,2	
	-10		168,3	70,5	159,4	77,4	150,2	85,0	140,2	93,4		
	-8		183,3	71,7	173,7	78,6	163,8	86,2	153,3	94,5		
	-4		214,4	74,1	203,9	81,1	192,3	88,7	180,4	97,2	165,1	108,2
	0	248,5	77,1	237,2	84,0	224,5	91,6	211,1	100,0	193,2	111,2	
	Pure water	5	303,6	81,8	289,3	88,8	273,6	96,4	257,3	104,9	236,5	116,2
		7	324,0	83,5	308,0	90,5	291,5	100,0	273,9	106,7	251,8	118,1
		12	376,4	87,8	358,2	95,1	338,3	102,9	318,1	111,5	293,0	122,5
		15	410,6	90,7	389,9	98,0	367,1	106,3	346,2	114,5	319,4	125,3
		18	445,6	93,6	423,0	101,1	399,5	109,0	375,5	117,5	346,8	128,3

Pf: Cooling capacity valid for delta T according to operating limits
 Pa: Power input
 Pc: Heating capacity valid for delta T according to operating limits

Mandatory glycol water utilization zone
 Calculation fouling factor 0,0005 m² °C/W
 EUROVENT conditions (EN 14511)



COOLING CAPACITIES



COOLING ONLY models

LD LDC LDH	Evaporator water outlet temperature °C	INLET AIR TEMPERATURE AT THE CONDENSER °C										
		25		30		35		40		46		
		Pf kW	Pa kW	Pf kW	Pa kW	Pf kW	Pa kW	Pf kW	Pa kW	Pf kW	Pa kW	
80V	Glycol water	-12	10,7	4,8	10,0	5,3	9,2	5,9	8,3	6,6		
		-10	11,6	4,9	10,8	5,4	10,0	6,0	9,2	6,6		
		-8	12,6	5,0	11,7	5,5	10,9	6,1	10,0	6,7		
		-4	14,6	5,1	13,7	5,7	12,8	6,3	11,8	6,9		
	Pure water	0	16,8	5,3	15,8	5,9	14,8	6,5	13,7	7,1	12,3	8,0
		5	20,4	5,6	19,2	6,2	17,9	6,8	16,7	7,4	15,1	8,3
		7	21,8	5,7	20,6	6,3	19,3	7,04	18,0	7,5	16,3	8,4
		12	25,2	6,0	23,8	6,6	22,3	7,2	20,8	7,9	19,0	8,7
90V	Glycol water	15	27,4	6,2	25,9	6,8	24,3	7,4	22,7	8,1	20,7	8,9
		-12	12,2	5,6	11,4	6,2	10,5	6,8	9,5	7,6		
		-10	13,3	5,7	12,4	6,2	11,5	6,9	10,4	7,7		
		-8	14,3	5,8	13,5	6,3	12,5	7,0	11,4	7,8		
	Pure water	-4	16,7	5,9	15,7	6,5	14,6	7,2	13,5	8,0		
		0	19,1	6,1	18,0	6,8	16,9	7,4	15,7	8,2		
		5	22,9	6,5	21,8	7,1	20,4	7,8	19,0	8,6	17,8	9,5
		7	24,5	6,7	23,2	7,3	21,8	8,16	20,4	8,8	19,2	9,6
100V	Glycol water	12	28,2	7,1	26,7	7,7	25,1	8,4	23,5	9,2	22,3	10,0
		15	30,6	7,4	28,9	8,0	27,2	8,7	25,5	9,5	24,3	10,2
		-12	14,5	6,4	13,5	7,1	12,5	7,8	11,3	8,7		
		-10	15,7	6,5	14,6	7,2	13,6	7,9	12,4	8,8		
	Pure water	-8	16,9	6,6	15,9	7,3	14,8	8,0	13,6	8,9		
		-4	19,7	6,8	18,5	7,5	17,2	8,3	15,9	9,1		
		0	22,6	7,0	21,2	7,7	19,9	8,5	18,4	9,4		
		5	27,1	7,4	25,6	8,1	23,9	8,9	22,2	9,8	20,3	11,0
120V	Glycol water	7	29,0	7,5	27,4	8,3	25,7	9,31	23,9	10,0	21,8	11,1
		12	33,5	7,9	31,6	8,7	29,7	9,5	27,7	10,4	25,3	11,5
		15	36,3	8,2	34,3	9,0	32,3	9,8	30,1	10,7	27,6	11,8
		-12	16,2	7,5	15,0	8,3	13,9	9,1	12,6	10,1		
	Pure water	-10	17,5	7,7	16,4	8,4	15,2	9,3	13,9	10,2		
		-8	19,0	7,8	17,7	8,6	16,5	9,4	15,2	10,3		
		-4	21,9	8,0	20,6	8,8	19,2	9,7	17,7	10,6		
		0	25,2	8,3	23,6	9,1	22,1	10,0	20,5	10,9		
150V	Glycol water	5	30,2	8,8	28,4	9,6	26,6	10,5	24,7	11,4	22,4	12,7
		7	32,2	9,0	30,4	9,8	28,4	11,0	26,4	11,7	24,0	12,9
		12	37,1	9,5	34,9	10,3	32,8	11,2	30,5	12,1	27,9	13,3
		15	40,1	9,8	37,8	10,6	35,5	11,5	33,1	12,5	30,3	13,6
	Pure water	-12	21,2	9,5	20,1	10,4	18,9	11,2	17,2	12,2		
		-10	22,8	9,7	21,7	10,6	20,3	11,5	18,6	12,4		
		-8	24,6	9,9	23,3	10,9	21,9	11,8	20,4	12,8		
		-4	28,3	10,4	26,8	11,3	25,2	12,4	23,6	13,5		
180V	Glycol water	0	32,4	10,8	30,7	11,9	28,9	12,9	26,9	14,1		
		5	38,0	11,5	35,9	12,6	33,8	13,7	31,5	14,8	29,0	16,3
		7	40,4	11,8	38,2	12,9	36,0	14,3	33,7	15,2	31,0	16,6
		12	46,5	12,5	43,9	13,6	41,4	14,8	38,9	16,0	36,0	17,1
	Pure water	15	50,2	13,0	47,5	14,1	44,8	15,3	42,1	16,5		
		-12	24,8	10,7	23,0	11,9	21,3	13,2	19,2	14,6		
		-10	26,7	10,9	25,1	12,0	23,3	13,4	21,1	14,8		
		-8	28,9	11,0	27,3	12,2	25,3	13,5	23,3	15,0		
Pure water	-4	33,6	11,4	31,8	12,6	29,6	13,9	27,5	15,4			
	0	38,5	11,8	36,6	13,0	34,3	14,3	31,9	15,8			
	5	46,4	12,5	44,0	13,7	41,4	15,0	38,7	16,5	35,5	18,5	
	7	49,6	12,8	47,1	14,0	44,3	15,7	41,6	16,8	38,1	18,8	
Pure water	12	57,2	13,6	54,2	14,8	51,1	16,1	48,1	17,6	44,3	19,5	
	15	62,0	14,1	58,7	15,4	55,4	16,7	52,1	18,2	48,2	20,0	

Pf: Cooling capacity valid for delta T according to operating limits
 Pa: Power input
 Pc: Heating capacity valid for delta T according to operating limits

Light blue: Mandatory glycol water utilization zone
 Dark blue: Calculation fouling factor 0,00005 m² °C/W
 Blue: EUROVENT conditions (EN 14511)



Water chillers

COOLING CAPACITIES



COOLING ONLY models

LD LDC LDH	Evaporator water outlet temperature °C	INLET AIR TEMPERATURE AT THE CONDENSER °C										
		25		30		35		40		46		
		Pf kW	Pa kW	Pf kW	Pa kW	Pf kW	Pa kW	Pf kW	Pa kW	Pf kW	Pa kW	
200V	Glycol water	-12	27,8	12,7	26,2	14,1	24,2	15,7	22,0	17,4		
		-10	30,6	13,0	28,6	14,4	26,5	16,0	24,1	17,6		
		-8	33,1	13,2	31,0	14,7	28,8	16,2	26,4	17,9		
		-4	38,3	13,8	36,0	15,2	33,5	16,8	31,0	18,6		
		0	44,0	14,3	41,4	15,8	38,6	17,4	35,8	19,2	32,4	21,5
Pure water	5	52,6	15,3	49,7	16,8	46,5	18,4	43,3	20,2	39,4	22,4	
	7	56,4	15,7	53,1	17,2	49,8	19,2	46,4	20,6	42,3	22,8	
	12	64,8	16,7	61,1	18,2	57,3	19,8	53,6	21,6	49,0	23,7	
	15	70,1	17,3	66,2	18,9	62,1	20,5	58,2	22,2	53,4	24,3	
	240V	Glycol water	-12	32,7	14,9	30,7	16,4	28,4	18,0	25,8	19,8	
-10			35,6	15,1	33,3	16,6	31,0	18,3	28,5	20,1		
-8			38,5	15,3	36,2	16,8	33,6	18,5	31,0	20,3		
-4			44,7	15,8	42,1	17,3	39,2	19,0	36,3	20,8	32,7	23,3
0			51,3	16,2	48,5	17,8	45,3	19,5	42,1	21,3	38,2	23,8
Pure water	5	61,9	17,0	58,5	18,6	54,8	20,3	51,0	22,2	46,5	24,6	
	7	66,2	17,4	62,5	18,9	58,7	21,0	54,8	22,5	50,0	24,9	
	12	76,4	18,2	72,3	19,8	68,0	21,5	63,5	23,3	58,2	25,8	
	15	83,0	18,8	78,5	20,4	73,9	22,1	69,1	23,9	63,5	26,2	
	300V	Glycol water	-12	42,1	19,1	40,0	20,8	37,5	22,6	34,4	24,6	
-10			45,6	19,5	43,2	21,3	40,6	23,2	37,6	25,1		
-8			49,2	20,0	46,6	21,8	43,9	23,7	40,8	25,7		
-4			56,8	20,8	53,7	22,7	50,6	24,8	47,2	26,9		
0			64,7	21,7	61,5	23,8	57,9	25,9	54,1	28,1	49,5	30,8
Pure water	5	76,1	22,9	72,2	25,1	68,0	27,3	63,7	29,6	58,5	32,4	
	7	81,1	23,5	76,9	25,6	72,4	28,5	67,9	30,2	62,6	33,1	
	12	93,5	24,9	88,5	27,1	83,4	29,4	78,3	31,7	72,5	34,7	
	15	101,1	25,9	95,8	28,1	90,3	30,4	85,0	32,8	78,7	34,8	
	350V	Glycol water	-12	48,1	21,6	45,6	23,6	42,8	25,7	39,7	28,1	
-10			52,5	22,0	49,7	23,9	46,8	26,1	43,7	28,6		
-8			57,1	22,3	54,1	24,3	50,9	26,5	47,6	29,0		
-4			66,7	23,0	63,4	25,1	59,7	27,4	56,0	29,9		
0			77,3	23,7	73,4	25,9	69,2	28,3	64,9	30,9	59,6	34,4
Pure water	5	92,5	24,9	87,5	27,0	82,7	29,5	77,6	32,2	71,4	35,8	
	7	99,0	25,3	94,0	27,6	88,7	30,6	83,2	32,8	76,7	36,4	
	12	115,6	26,6	109,6	28,9	103,4	31,4	97,1	34,2	89,7	37,8	
	15	126,0	27,5	119,7	29,8	112,8	32,4	106,1	35,2	98,2	38,8	
	18	137,0	28,5	130,1	30,8	122,8	33,4	115,6	36,2	107,3	39,8	
400V	Glycol water	-12	53,6	24,8	50,6	27,1	47,3	29,6				
		-10	58,5	25,3	55,3	27,6	51,9	30,1				
		-8	63,5	25,7	60,2	28,1	56,5	30,7	52,5	33,4		
		-4	74,3	26,6	70,5	29,1	66,4	31,8	61,9	34,6		
		0	85,7	27,6	81,5	30,2	76,8	32,9	71,9	35,9	65,6	39,6
Pure water	5	102,3	29,0	96,9	31,6	91,5	34,5	85,7	37,5	78,4	41,4	
	7	109,3	29,6	103,8	32,3	97,9	35,9	91,9	38,2	84,2	42,1	
	12	127,1	31,2	120,7	33,9	113,8	36,8	106,7	39,9	98,3	43,8	
	15	138,6	32,3	131,3	35,0	123,9	37,9	116,3	41,0	107,3	44,8	
	18	150,5	33,4	142,5	36,1	134,5	39,0	126,4	42,1	116,9	45,9	
500V	Glycol water	-12	66,4	30,9	62,4	33,8	58,1	36,9	53,0	40,3		
		-10	72,4	31,5	68,2	34,4	63,8	37,6	58,8	41,0		
		-8	78,7	32,1	74,3	35,1	69,6	38,3	64,5	41,7		
		-4	92,1	33,3	87,1	36,4	81,9	39,7	76,2	43,2		
		0	106,4	34,6	100,8	37,7	94,9	41,1	88,6	44,8	80,6	49,4
Pure water	5	128,7	36,7	122,0	39,9	115,0	43,4	107,5	47,0	98,3	51,8	
	7	138,1	37,6	130,8	40,8	123,3	45,2	115,5	48,0	105,8	52,7	
	12	160,0	39,8	151,6	43,0	142,9	46,6	134,0	50,3	123,1	54,9	
	15	173,1	41,2	164,7	44,5	155,3	48,0	145,7	51,7	134,0	56,2	
	18	188,5	42,7	178,5	46,0	168,2	49,5	157,9	53,2			
540V	Glycol water	-12	74,4	34,0	69,9	37,3	65,3	40,7	59,6	44,5		
		-10	80,5	34,6	75,9	37,9	70,9	41,5	65,3	45,3		
		-8	87,2	35,3	82,0	38,6	76,7	42,3	71,1	46,2		
		-4	100,6	36,5	95,0	40,0	88,9	43,9	82,8	47,8		
		0	115,2	37,8	109,0	41,5	102,3	45,4	95,3	49,5	86,8	54,7
Pure water	5	138,3	39,9	130,9	43,6	123,0	47,6	114,9	51,9	105,1	57,2	
	7	147,8	40,8	140,0	44,5	131,6	49,8	123,2	52,8	112,9	58,2	
	12	170,6	42,9	161,5	46,7	152,0	50,7	142,5	55,0	131,2	60,3	
	15	185,0	44,3	175,2	48,1	165,0	52,2	154,9	56,5	142,5	60,8	

Pf: Cooling capacity valid for delta T according to operating limits
 Pa: Power input
 Pc: Heating capacity valid for delta T according to operating limits

Light blue: Mandatory glycol water utilization zone
 Dark blue: Calculation fouling factor 0,00005 m² °C/W
 Blue: EUROVENT conditions

AQUACIAT 2

R410A
LOW NOISE - LN



COOLING CAPACITIES



COOLING ONLY models

LD LDC LDH	Evaporator water outlet temperature °C	INLET AIR TEMPERATURE AT THE CONDENSER °C										
		25		30		35		40		46		
		Pf kW	Pa kW	Pf kW	Pa kW	Pf kW	Pa kW	Pf kW	Pa kW	Pf kW	Pa kW	
600V	Glycol water	-12	83,3	38,2	78,7	41,8	73,8	45,3				
		-10	90,1	39,1	85,4	42,7	80,1	46,4	74,0	50,5		
		-8	96,9	40,1	92,1	43,7	86,5	47,6	80,4	51,6		
		-4	112,2	41,6	106,1	45,6	99,9	49,7	93,2	53,9		
		0	128,1	43,3	121,5	47,5	114,3	51,7	106,8	56,2		
	Pure water	5	153,1	46,0	145,3	50,3	136,8	54,8	128,0	59,5	117,6	65,2
		7	163,5	47,0	155,3	51,5	146,1	57,0	136,9	60,7	126,1	66,5
		12	188,6	49,8	178,4	54,2	168,1	58,8	157,8	63,6	146,1	69,4
		15	204,1	51,6	193,3	56,0	182,2	60,6	171,3	65,4		
		18	220,4	53,5	208,7	57,9	196,9	62,5	185,7	67,3		
700V	Glycol water	-12	91,6	43,3	87,1	47,5						
		-10	99,9	44,3	94,5	48,4						
		-8	108,3	45,1	102,4	49,4	96,1	54,0				
		-4	125,8	47,0	119,3	51,4	112,1	56,1	104,6	61,3		
		0	144,4	48,9	137,1	53,5	128,9	58,3	120,7	63,6		
	Pure water	5	175,3	52,2	166,7	57,0	157,3	62,1	147,4	67,5	136,1	74,4
		7	187,1	53,6	177,1	58,4	167,0	65,0	156,7	68,8	145,0	75,8
		12	216,1	57,0	204,6	61,8	193,1	67,0	181,8	72,5	168,9	79,3
		15	234,3	59,3	222,2	64,2	209,8	69,3	197,8	74,8		
		18	253,6	61,7	240,4	66,6	227,3	71,8	214,9	77,4		
702V	Glycol water	-12	97,9	42,3	92,5	46,1	87,0	50,5	80,5	55,3		
		-10	107,3	42,9	101,1	46,8	95,3	51,2	89,1	56,0		
		-8	116,1	43,6	110,0	47,5	103,7	51,9	97,1	56,9		
		-4	135,8	44,9	129,1	49,0	121,7	53,6	114,2	58,6	104,6	65,5
		0	158,1	46,4	150,4	50,6	142,1	55,3	133,6	60,6	122,8	67,5
	Pure water	5	192,8	48,9	183,4	53,2	173,2	58,1	162,8	63,5	150,0	70,6
		7	206,1	49,9	195,4	54,2	184,7	60,5	173,9	64,5	160,1	71,7
		12	239,5	52,5	227,6	57,0	215,0	62,0	202,2	67,5	187,3	74,7
		15	261,2	54,3	248,2	58,8	234,4	63,8	220,7	69,4	204,7	76,6
		18	283,9	56,2	269,7	60,9	254,8	66,0	240,2	71,5	223,3	78,8
800V	Glycol water	-12	109,0	48,6	103,0	53,1	96,4	57,9	88,9	63,2		
		-10	118,9	49,4	112,7	54,1	105,7	59,0	98,1	64,4		
		-8	129,3	50,3	122,5	55,0	115,5	60,1	107,6	65,6		
		-4	151,1	52,0	143,4	56,9	135,4	62,2	126,6	67,9	115,2	75,2
		0	175,2	53,9	167,2	59,1	157,8	64,5	147,9	70,5	135,3	78,0
	Pure water	5	213,0	57,1	202,9	62,3	191,7	68,0	180,1	74,1	165,3	81,8
		7	227,3	58,3	216,0	63,6	204,1	70,6	191,7	75,4	176,3	83,2
		12	263,7	61,5	250,5	66,9	236,8	72,6	222,5	78,8	205,2	86,6
		15	286,9	63,7	272,8	69,1	257,5	74,8	242,3	81,0	223,9	88,7
		18	311,3	66,0	295,6	71,4	279,3	77,1	262,9	83,3	243,4	91,0
900V	Glycol water	-12	131,7	56,7	125,0	62,4	118,1	68,7	110,7	75,6		
		-10	143,2	57,7	136,3	63,3	128,8	69,6	120,9	76,5		
		-8	155,8	58,5	147,9	64,3	139,8	70,6	131,4	77,4		
		-4	181,4	60,4	172,5	66,3	162,9	72,7	153,3	79,6	141,2	88,8
		0	210,7	62,7	200,7	68,6	189,9	75,0	178,4	82,2	164,4	91,4
	Pure water	5	257,2	66,5	243,6	72,3	230,3	79,0	216,6	86,1	199,8	95,4
		7	272,8	67,7	259,7	73,8	245,8	81,7	230,8	87,7	212,9	97,0
		12	317,7	71,7	301,3	77,8	284,2	84,6	267,7	91,8	247,6	101,0
		15	345,9	74,4	328,1	80,5	310,0	87,3	291,7	94,5	269,9	103,6
		18	375,3	77,3	356,0	83,5	336,3	90,3	317,0	97,3	293,4	106,5
1000V	Glycol water	-12	140,2	62,5	132,9	68,6	125,6	75,6	117,5	83,5		
		-10	153,2	63,4	145,2	69,6	137,1	76,6	128,7	84,5		
		-8	166,8	64,4	158,0	70,7	149,2	77,7	140,0	85,5		
		-4	195,3	66,8	185,2	73,0	174,5	80,0	164,1	87,9	151,1	98,4
		0	226,1	69,7	215,8	75,9	203,9	82,8	191,5	90,6	176,1	101,3
	Pure water	5	274,5	74,1	262,2	80,5	247,7	87,5	232,7	95,5	214,6	106,0
		7	294,4	75,9	279,0	82,2	263,7	91,0	248,0	97,2	228,6	107,8
		12	341,2	80,2	323,7	86,9	306,1	94,1	287,9	102,0	266,2	112,4
		15	371,6	83,1	352,4	89,8	333,0	97,1	313,4	105,1	290,1	115,5
		18	402,7	86,1	382,0	93,0	360,9	100,3	339,8	108,3	315,2	118,6
1100V	Glycol water	-12	151,1	68,8	143,8	75,9	135,2	83,5	125,8	91,9		
		-10	165,9	70,2	157,2	77,2	148,0	84,8	138,0	93,2		
		-8	180,5	71,6	171,1	78,5	161,0	86,2	150,7	94,5		
		-4	210,7	74,3	200,3	81,4	188,7	89,2	176,8	97,6	162,0	108,7
		0	244,4	77,8	232,6	84,7	219,8	92,4	206,2	100,8	187,2	111,8
	Pure water	5	296,3	82,9	282,3	90,2	266,6	97,9	250,4	106,6	229,8	117,7
		7	315,9	84,9	300,0	92,1	283,6	102,0	266,4	108,5	244,8	119,6
		12	365,6	89,9	347,2	97,4	328,0	105,3	308,2	113,8	283,9	124,7
		15	397,5	93,2	377,1	100,7	356,0	108,5	334,5	117,1	308,7	127,8
		18	430,1	96,6	407,8	104,1	385,0	112,0	362,0	120,4		

Pf: Cooling capacity valid for delta T according to operating limits
 Pa: Power input
 Pc: Heating capacity valid for delta T according to operating limits

Mandatory glycol water utilization zone
 Calculation fouling factor 0,0005 m² °C/W
 EUROVENT conditions (EN 14511)

DEGIPAC DEFROST SYSTEM ILDC-ILDH-ILDH

DEGIPAC defrost principle

This system, present as a standard feature on CIAT's CONNECT control system, makes it possible to defrost in a convenient way a coil of an air/water heat pump.

Thanks to a regular examination of several reference parameters in order to estimate the frost cover, such as the evaporating temperature of refrigerant and the outdoor air temperature, DEGIPAC starts the defrost only when it is really necessary, and defines the time just necessary to a perfect defrosting of fins of the air coil exchanger.

Compared with a traditional defrosting cycle with timer, DEGIPAC offers an improvement of 5% thus on average of the seasonal COP and it makes it possible to divide by 2 the number of defrosts over one season.

The result is an increased reliability of the heat pumps as well as an excellent optimization of the cycles frequency by privileging the cold and wet periods.

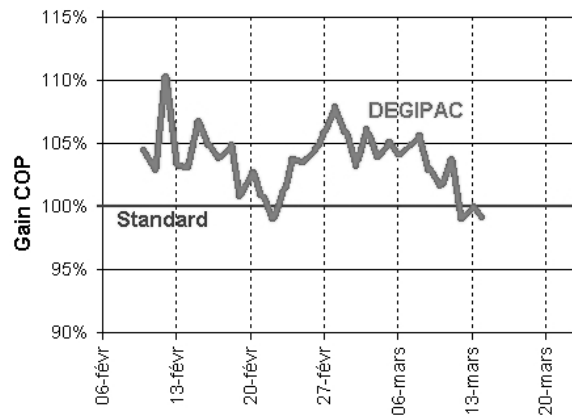

AUXILIARY HEATING MANAGEMENT

In function of the outdoor temperature and of the heating capacity required in winter, an additional extra heating system can be used in addition to the thermodynamic heat pump.

Three running conditions are possible on HEATING mode:

- thermodynamic heating only (heat pump),
- thermodynamic with some electric heaters in addition,
- water heating only with all electric heaters.

These electric water heaters can be of external supply, or a CIAT supply like the electric loop heater or the ME electric water heater modules, and up to a maximum of 4 capacity stages.

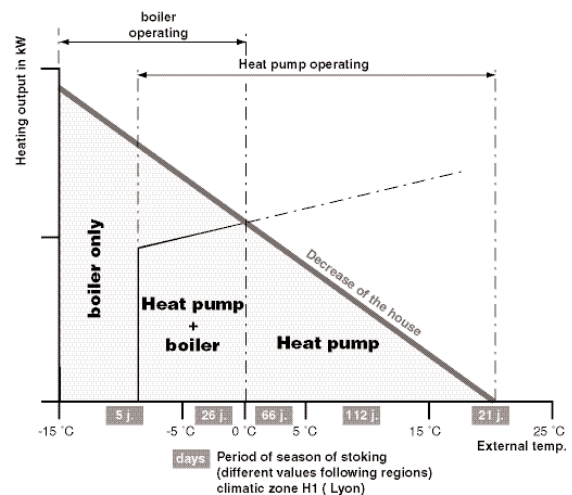

AUXILIARY HEATING MANAGEMENT BOARD (80V TO 1100V)

The auxiliary heating management board is an optional accessory allowing to a reversible Aquaciat 2 machine the control of 4 additional capacity stages in HEATING mode. According to the models or the versions of units, this board is either a separately delivered kit, or a factory mounted optional equipment mounted in the factory un request.

ELECTRIC LOOP HEATER 15 kW (80V TO 150V)

The AquaCiat2 reversible heat pump can be equipped in option and according to the sizes 80V to 150V of an electric loop heater of 15 kW to install indoor.



Heating capacity	15 kW (5 kW + 10 kW)
Heaters constitution	(3 x 1.66 kW) + (6 x 1.66 kW)
Electric main supply	3ph-50Hz 400V + Earth
MAXI rated current *	24.0 A
Control voltage	1ph-50Hz 230V + Earth
Unit protection index	IP 44
Maximum number of stages	2

Capacity stages kW	5 + 10
Maximum setting temperature	+60°C
Maximum water flow	4.0 m³/h
Maximum operating pressure	7 bars
Water connections	G 1 1/4"
HxLxW dimensions	252 x 631 x 155 mm
Weight without charge	15 kg

* **Caution:** the rated current indicated in the above table must be added to the maximum rated current of the ILDC-ILDH machine, total value necessary to the dimensioning of the supply electric cable of the "ILDC-ILDH + ME" assembly
 * 40% MPG maximum



ELECTRIC WATER HEATER SYSTEM

CAPACITIES 15, 30, 45 OR 60 kW (180V TO 300V)

Main description

On models 180V to 300V, this electric water heater module from CIAT allows a simple and economic solution, by an additional electric boiler to obtain a safety in heating, in particular in heat pump mode by very low outside temperature.

This additional heating is particularly recommended for the applications of heating by heat pump, in the fields such as hotel, residential building or some administration buildings.

Technical specifications

Specially designed for AquaCiat2 reversible units, ILDC & ILDH 180V to 300V models, the water heater is an option separately delivered.

It is ready to be mounted and fixed on the spot in the prolongation of the casing of the reversible unit, of which it allows also the power supply from the same supply terminal strip, while respecting preoccupations with an aesthetic unit on site.

It is completely controlled by the heat pump during the operation in HEATING mode, thanks to the optional extra heating control card (accessory to purchase) within the limit of a maximum of 4 capacity step controls.

Electrical specifications

	ME 15	ME 30	ME 45	ME 60
Heating capacity	15 kW	30 kW	45 kW	60 kW
Capacity steps kW	5 + 10	10 + 20	15 + 30	20 + 40
Electric main supply	3ph~50Hz 400V + Earth			
MAXI rated current *	24.0 A	48.0 A	72.0 A	96.0 A
Control voltage	1ph~50Hz 230V + Earth			
Unit protection	IP 44			
Maximum step control	2	4	4	4
Maximum outlet temperature	+60°C			
Maximum water flow	4.0 m³/h	8.0 m³/h	12.0 m³/h	16.0 m³/h
Maximum operating pressure	4 bars			
Water connections	G 1 1/4" Male			
HxLxW dimensions	1671 x 681 x 1055 mm			
Mass empty	145 kg	160 kg	175 kg	191 kg
Mass in operation	169 kg	182 kg	195 kg	208 kg

* **Caution:** the rated current indicated in the above table must be added to the maximum rated current of the ILDC-ILDH machine, total value which necessary to the dimensioning of the supply electric cable of the "ILDC-ILDH + ME" assembly

Electric water heater module description

Equipped with a self controlled frozen protection mounted in factory, the electric water heater system is delivered in a packaged technical casing of comparable nature that of the reversible machine, allowing an outside installation under adverse weather.

According to the user's request on the spot, it is available in 4 electric outputs: 15 kW, 30 kW, 45 kW or 60 kW.

■ Factory standard equipment:

- Main switch and power terminal strip
- Contactors, circuit breakers protections
- Electric water heater(s)
- Safety relief vale, automatic air purge
- Control valve for water by-pass
- Frozen protection with temperature control
- Painted cabinet for outdoor installation
- Electric power wires 3ph-400V-50Hz for supply from water heater system to ILDC-ILDH unit
- Wires for the control of electric heaters
- Thermal insulation of water pipes

Note:

- the optional "extra heating control card" of Connect is essential to control additional electric heaters,
- a water filter is absolutely necessary on the water inlet.



Water chillers

Water pressure drops, electrical module ME

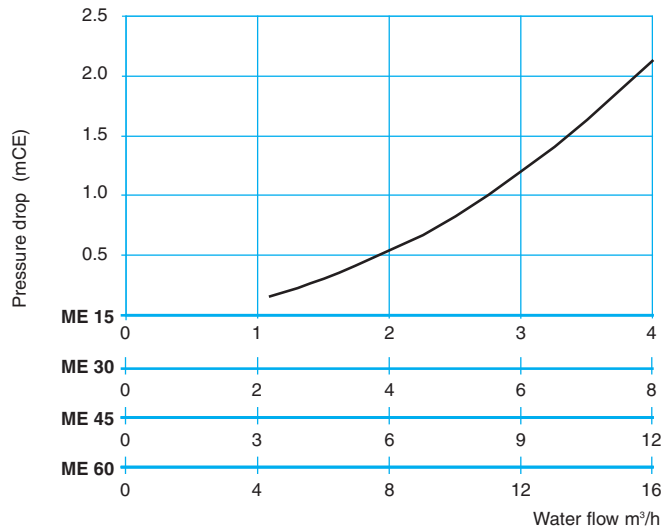

Note: the water pressure drop of the ME electric water heater must be added to the machine pressure drop, ILDC - ILDC -ILDH.

ILDC 180 - 300V series (without water tank)

Example of unit:

- standard machine, ILDC 180-300V model
- electric auxiliary heater module 45kW (3 x 15kW)

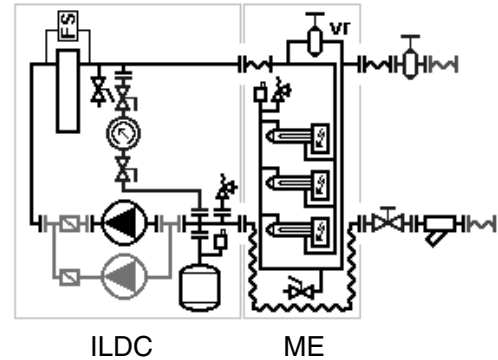
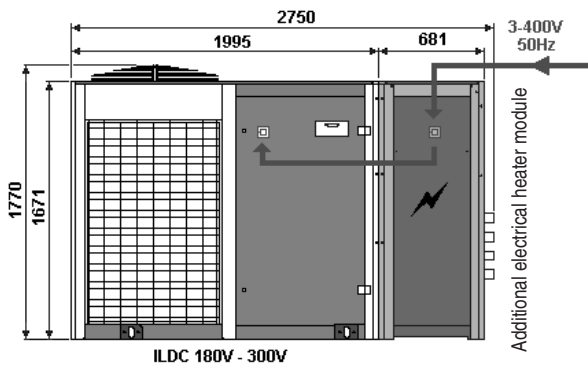

ILDH 180 to 300V series (with water tank)

Example of unit:

- standard machine, ILDC 180-300V model
- standard water buffer tank, MH 180-300 model
- electric auxiliary heater module 45kW (3 x 15kW)

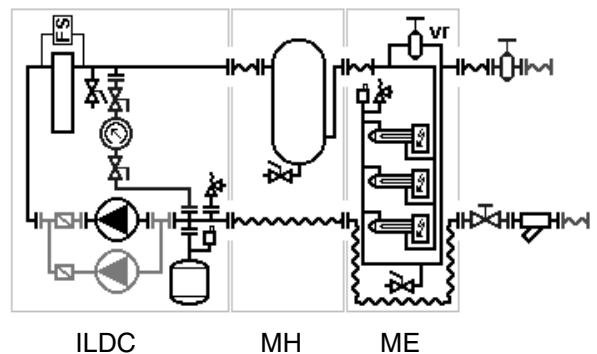
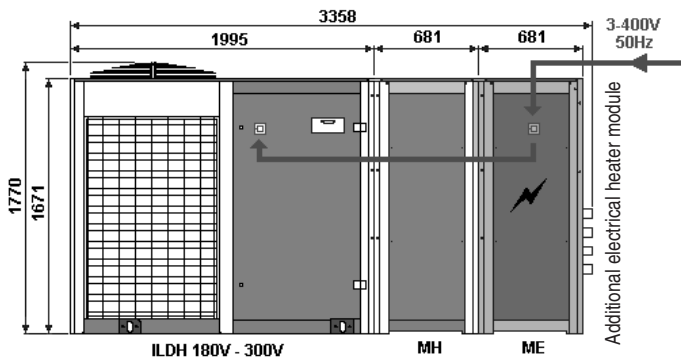

Note: above field diagrams examples are only indicative and do not purport to show the installation details necessary.

COOLING CAPACITIES



Reversible models

ILD ILDC ILDH	Evaporator water outlet temperature °C	INLET AIR TEMPERATURE AT THE CONDENSER °C										
		25		30		35		40		46		
		Pf kW	Pa kW	Pf kW	Pa kW	Pf kW	Pa kW	Pf kW	Pa kW	Pf kW	Pa kW	
80V	Glycol water	-10	11,9	5,1	11,0	5,7	10,1	6,3	9,2	7,0		
		-8	13,0	5,1	12,1	5,7	11,2	6,4	10,2	7,1		
		-4	15,2	5,2	14,2	5,8	13,2	6,4	12,2	7,2	11,3	8,1
		0	17,5	5,3	16,5	5,9	15,4	6,6	14,3	7,3	12,8	8,2
	Pure water	5	21,3	5,6	20,1	6,2	18,8	6,8	17,5	7,5	15,8	8,5
		7	22,8	5,7	21,5	6,3	20,2	6,9	18,8	7,6	17,1	8,6
		12	26,5	6,0	25,1	6,6	23,6	7,2	22,0	7,9	20,1	8,8
		15	28,9	6,2	27,4	6,8	25,8	7,4	24,1	8,1	22,0	9,0
90V	Glycol water	-10	13,6	5,8	12,7	6,4	11,7	7,1	10,7	8,0		
		-8	14,8	5,8	13,9	6,5	12,9	7,2	12,0	8,1		
		-4	17,2	6,0	16,2	6,6	15,2	7,4	14,0	8,2	12,6	9,2
		0	19,9	6,2	18,8	6,8	17,6	7,5	16,4	8,3	14,7	9,4
	Pure water	5	23,8	6,5	22,7	7,1	21,3	7,8	19,9	8,6	18,2	9,7
		7	25,6	6,6	24,3	7,3	22,9	8,0	21,4	8,8	19,6	9,8
		12	29,6	7,0	28,1	7,7	26,5	8,4	24,9	9,2	22,9	10,2
		15	32,2	7,3	30,5	8,0	28,8	8,7	27,1	9,5	25,0	10,5
100V	Glycol water	-10	16,2	6,8	15,1	7,6	13,9	8,5	12,6	9,4		
		-8	17,6	6,9	16,4	7,7	15,2	8,5	13,9	9,5		
		-4	20,6	7,0	19,3	7,8	18,0	8,6	16,6	9,6	14,8	10,9
		0	23,7	7,1	22,4	7,9	21,0	8,7	19,4	9,7	17,6	11,0
	Pure water	5	28,8	7,4	27,2	8,2	25,6	9,0	23,8	9,9	21,6	11,2
		7	30,8	7,5	29,2	8,3	27,4	9,1	25,6	10,0	23,3	11,3
		12	35,9	7,8	34,0	8,6	32,0	9,4	29,9	10,3	27,4	11,6
		15	39,1	8,0	37,0	8,8	34,9	9,6	32,7	10,6	30,0	11,8
120V	Glycol water	-10	18,2	7,9	16,9	8,7	15,7	9,7	14,3	10,6		
		-8	19,8	8,0	18,5	8,8	17,1	9,8	16,0	10,7		
		-4	23,1	8,2	21,7	9,0	20,2	9,9	18,6	10,9	16,5	12,3
		0	26,6	8,4	25,1	9,2	23,4	10,1	21,7	11,1	19,6	12,5
	Pure water	5	32,1	8,7	30,3	9,5	28,5	10,4	26,5	11,4	24,0	12,8
		7	34,4	8,9	32,5	9,7	30,5	10,6	28,4	11,6	25,9	12,9
		12	39,8	9,2	37,7	10,1	35,5	11,0	33,2	12,0	30,3	13,3
		15	43,3	9,5	41,1	10,3	38,7	11,2	36,2	12,2	33,2	13,5
150V	Glycol water	-10	24,1	9,7	22,8	10,6	21,4	11,6	19,9	12,8		
		-8	26,0	9,8	24,7	10,7	23,2	11,8	21,7	12,9	19,3	14,4
		-4	30,2	10,0	28,7	10,9	27,1	12,0	25,4	13,2	23,2	14,7
		0	34,7	10,2	33,1	11,2	31,3	12,3	29,4	13,5	26,9	15,0
	Pure water	5	42,0	10,6	40,0	11,7	37,9	12,8	35,6	14,0	32,7	15,6
		7	44,9	10,8	42,8	11,8	40,5	13,0	38,2	14,2	35,1	15,8
		12	52,3	11,2	49,7	12,3	47,1	13,5	44,4	14,7	41,0	16,4
		15	56,8	11,6	54,1	12,7	51,3	13,8	48,3	15,1	44,8	16,8
180V	Glycol water	-10	27,7	11,2	25,9	12,5	23,9	13,9	21,5	15,7		
		-8	30,1	11,3	28,3	12,5	26,3	14,0	23,9	15,6		
		-4	35,2	11,5	33,3	12,7	31,1	14,1	28,8	15,7	25,5	17,9
		0	40,6	11,8	38,5	13,0	36,3	14,4	33,7	15,9	30,5	18,1
	Pure water	5	49,2	12,3	46,7	13,5	44,0	14,9	41,3	16,4	37,7	18,5
		7	52,6	12,5	50,0	13,8	47,1	15,2	44,3	16,7	40,6	18,8
		12	61,1	13,2	57,9	14,5	54,8	15,8	51,6	17,3	47,6	19,4
		15	66,4	13,7	63,1	15,0	59,6	16,3	56,2	17,8	52,0	19,8

Pf: Cooling capacity valid for delta T according to operating limits
 Pa: Power input
 Pc: Heating capacity valid for delta T according to operating limits

Mandatory glycol water utilization zone
 Calculation fouling factor 0,00005 m² °C/W
 EUROVENT conditions (EN 14511)



Water chillers

COOLING CAPACITIES



Reversible models

ILD ILDC ILDH	Evaporator water outlet temperature °C	INLET AIR TEMPERATURE AT THE CONDENSER °C										
		25		30		35		40		46		
		Pf kW	Pa kW	Pf kW	Pa kW	Pf kW	Pa kW	Pf kW	Pa kW	Pf kW	Pa kW	
200V	Glycol water	-10	31,9	13,1	29,8	14,6	27,5	16,3				
		-8	34,7	13,3	32,4	14,8	30,0	16,4	27,5	18,3		
		-4	40,5	13,7	38,0	15,2	35,4	16,8	32,7	18,7	29,0	21,1
		0	46,6	14,1	43,9	15,6	41,0	17,3	38,1	19,1	34,4	21,6
	Pure water	5	56,0	14,8	52,8	16,3	49,5	18,1	46,4	19,9	42,1	22,2
		7	60,3	15,1	57,0	16,6	53,5	18,3	49,9	20,2	45,5	22,5
		12	69,9	15,9	66,1	17,5	62,2	19,1	58,2	21,0	53,3	23,3
15	75,9	16,5	71,9	18,0	67,8	19,7	63,4	21,5	58,1	23,9		
240V	Glycol water	-10	36,1	15,7	33,7	17,3	31,1	19,1	28,0	21,2		
		-8	39,4	15,8	36,8	17,4	34,1	19,2	31,2	21,3		
		-4	46,2	16,0	43,5	17,6	40,5	19,4	37,5	21,5	33,3	24,2
		0	53,6	16,4	50,6	18,0	47,3	19,8	43,9	21,8	39,6	24,5
	Pure water	5	64,9	17,0	61,3	18,6	57,7	20,4	53,7	22,4	48,8	25,0
		7	69,6	17,3	65,8	18,9	61,9	20,7	57,7	22,7	52,6	25,3
		12	80,8	18,1	76,6	19,7	72,2	21,5	67,6	23,4	61,9	26,0
15	88,1	18,6	83,6	20,2	78,8	21,9	73,8	23,9	67,8	26,4		
300V	Glycol water	-10	45,4	19,7	43,0	21,6	40,4	23,5	37,3	25,7		
		-8	49,2	20,0	46,6	21,9	43,9	23,9	40,8	26,1		
		-4	57,0	20,7	54,2	22,7	51,0	24,8	47,7	27,1	43,2	30,0
		0	65,6	21,4	62,3	23,5	58,8	25,7	55,0	28,1	50,3	31,1
	Pure water	5	78,8	22,5	74,9	24,7	70,7	27,1	66,3	29,6	61,0	32,6
		7	84,5	23,1	80,1	25,2	75,6	27,6	71,0	30,1	65,4	33,2
		12	97,6	24,2	92,6	26,5	87,5	28,9	82,3	31,4	76,2	34,6
15	106,0	25,1	100,6	27,3	95,0	29,7	89,4	32,3	83,2	35,5		
350V	Glycol water	-10	52,9	23,6	50,0	25,7	46,9	28,1	43,3	30,8		
		-8	57,7	23,8	54,7	25,9	51,3	28,4	47,7	31,1		
		-4	68,0	24,3	64,4	26,5	60,6	29,0	56,6	31,8	51,4	35,6
		0	79,2	25,0	75,0	27,2	70,7	29,7	66,2	32,6	60,5	36,3
	Pure water	5	94,7	25,9	89,8	28,2	84,8	30,8	79,5	33,7	73,1	37,5
		7	103,7	26,6	98,3	28,8	92,8	31,4	87,2	34,3	80,3	38,2
		12	121,2	27,7	115,0	30,1	108,6	32,7	102,1	35,7	94,4	39,6
15	132,5	28,5	125,7	30,9	118,7	33,6	111,8	36,6	103,7	40,5		
18	144,0	29,5	136,7	32,0	129,0	34,6	121,8	37,7				
400V	Glycol water	-10	59,6	26,4	56,3	28,9	52,7	31,6	48,3	34,7		
		-8	65,1	26,6	61,7	29,2	57,9	31,9	53,6	34,9		
		-4	76,9	27,2	73,0	29,8	68,7	32,6	64,1	35,7	57,8	39,7
		0	89,3	27,9	84,9	30,5	80,2	33,4	75,1	36,5	68,3	40,6
	Pure water	5	108,7	29,1	103,5	31,7	97,9	34,7	91,9	37,9	84,1	42,0
		7	117,0	29,6	111,2	32,3	105,2	35,2	98,8	38,4	90,7	42,6
		12	136,4	30,9	129,8	33,6	122,9	36,6	115,6	39,8	106,5	44,0
15	149,1	31,9	141,8	34,5	134,2	37,5	126,3	40,7	116,7	45,0		
18	161,7	32,9	154,2	35,6	145,7	38,5	137,2	41,8				
500V	Glycol water	-10	73,3	32,6	69,1	35,7	64,3	39,1	58,8	42,8		
		-8	80,1	33,0	75,3	36,1	70,0	39,6	65,3	43,3		
		-4	94,4	33,8	89,2	37,0	84,5	40,5	78,1	44,4	70,1	49,5
		0	109,5	34,9	104,1	38,1	98,1	41,7	91,3	45,6	83,3	50,7
	Pure water	5	132,7	36,7	125,8	40,0	118,4	43,6	110,8	47,5	102,4	52,6
		7	141,7	37,4	135,5	40,7	128,1	44,4	119,5	48,4	109,8	53,5
		12	165,9	39,3	158,7	42,6	148,8	46,3	139,8	50,3	129,2	55,4
15	180,8	40,5	171,9	43,9	161,5	47,6	151,7	51,6	141,1	56,6		
18	197,0	42,0	187,0	45,4	176,4	49,1	165,9	53,0				

Pf: Cooling capacity valid for delta T according to operating limits
 Pa: Power input
 Pc: Heating capacity valid for delta T according to operating limits

Light blue: Mandatory glycol water utilization zone
 Yellow: Calculation fouling factor 0,00005 m² °C/W
 Dark blue: EUROVENT conditions (EN 14511)

AQUACIAT 2

R410A

HIGH PERFORMANCES - HP



COOLING CAPACITIES



Reversible models

R410A	HIGH PERFORMANCES - HP	ILD ILDC ILDH	Evaporator water outlet temperature °C	INLET AIR TEMPERATURE AT THE CONDENSER °C										
				25		30		35		40		46		
				Pf kW	Pa kW	Pf kW	Pa kW	Pf kW	Pa kW	Pf kW	Pa kW	Pf kW	Pa kW	
540V	Glycol water	-10	81,4	34,9	76,6	38,4	71,4	42,2	65,4	46,4				
		-8	89,6	35,2	83,5	38,7	78,1	42,5	72,0	46,8				
		-4	103,7	35,7	98,1	39,3	92,1	43,2	85,8	47,5	76,9	53,4		
		0	120,0	36,5	113,9	40,1	107,2	44,0	100,2	48,3	91,0	54,2		
	Pure water	5	145,3	37,8	138,2	41,5	130,4	45,5	122,2	49,9	111,9	55,7		
		7	155,9	38,5	148,2	42,1	139,9	46,1	131,3	50,6	120,4	56,3		
		12	181,4	40,1	172,6	43,8	163,2	47,8	153,4	52,2	141,3	58,0		
		15	198,0	41,3	188,3	44,9	178,2	48,9	167,7	53,3	154,9	59,1		
		600V	Glycol water	-10	91,2	38,5	86,3	42,2	81,2	46,1	74,9	50,6		
				-8	99,2	39,0	94,1	42,7	88,6	46,7	82,3	51,1		
-4	115,1			40,0	109,5	43,9	103,5	48,1	96,9	52,5	88,0	58,5		
0	132,8			41,1	126,5	45,1	119,6	49,5	112,4	54,1	103,0	60,2		
Pure water	5		160,5	42,9	153,1	47,2	144,9	51,6	136,1	56,6	125,3	62,8		
	7		172,1	43,7	164,0	47,9	155,3	52,5	146,0	57,4	134,6	63,8		
	12		200,2	45,8	190,5	50,1	180,4	54,7	170,0	59,7	157,4	66,1		
	15		218,3	47,3	207,6	51,5	196,7	56,1	185,4	61,1	172,1	67,5		
	18		237,4	48,8	225,7	52,9	213,9	57,5	202,2	62,5				
	700V		Glycol water	-10	95,7	42,8	90,6	46,7	84,1	51,1				
-8		105,1		43,6	99,5	47,6	93,6	52,1						
-4		121,4		45,0	114,6	49,2	108,2	53,7	101,3	58,5				
0		139,2		46,4	132,5	50,8	124,4	55,5	117,3	60,6	108,1	67,7		
Pure water		5	171,2	49,3	162,3	53,7	152,9	58,7	145,1	64,1	132,9	71,1		
		7	181,8	50,2	172,1	54,7	163,1	59,5	152,1	65,0	139,4	72,1		
		10	195,3	51,5	185,4	56,0	174,5	61,0	164,7	66,5	150,7	73,8		
		12	210,1	52,8	199,6	57,4	187,8	62,4	175,8	67,9				
		15	226,1	54,4	213,5	59,0	202,4	64,0	188,5	69,5				
		18	246,1	56,4	231,5	61,0	220,4	66,4	208,5	72,0				

Pf: Cooling capacity valid for delta T according to operating limits
 Pa: Power input
 Pc: Heating capacity valid for delta T according to operating limits

Mandatory glycol water utilization zone
 Calculation fouling factor 0,00005 m² °C/W
 EUROVENT conditions (EN 14511)

COOLING CAPACITIES



Reversible models

R410A	HIGH PERFORMANCES - HP	ILD ILDC ILDH	Température sortie d'eau à l'évaporateur °C	INLET AIR TEMPERATURE AT THE CONDENSER °C																
				25		30		35		40		45		46						
				Pf kW	Pa kW	Pf kW	Pa kW	Pf kW	Pa kW	Pf kW	Pa kW	Pf kW	Pa kW	Pf kW	Pa kW					
702V	Glycol water	-12	94,6	46,6	89,6	50,5	83,9	54,8	78,0	59,7										
		-10	103,5	47,1	97,7	51,2	92,0	55,4	85,8	60,4	78,5	65,9								
		-8	112,9	47,6	106,4	51,7	100,3	56,1	93,8	61,1	86,3	66,6	84,9	67,8						
		-4	132,4	48,6	125,5	52,7	118,3	57,3	110,7	62,4	102,7	68,0	101,1	69,2						
		0	153,0	49,6	145,1	53,8	136,9	58,4	128,4	63,6	119,4	69,4	117,6	70,6						
	Pure water	5	189,8	51,5	180,3	55,7	170,1	60,4	159,5	65,7	148,7	71,6	146,4	72,9						
		7	203,0	52,2	192,7	56,4	183,4	61,5	170,7	66,5	159,0	72,4	156,7	73,6						
		12	238,0	54,1	226,0	58,3	213,4	63,1	200,3	68,6	187,1	74,5	184,5	75,7						
		15	260,7	55,4	247,7	59,7	233,5	64,6	219,7	69,9	205,4	75,9	202,5	77,1						
		18	284,7	56,9	270,5	61,2	255,3	66,0	240,0	71,4	224,9	77,3	221,9	78,6						
	800V	Glycol water	-12	105,1	52,6	100,0	57,3	93,6	62,2	86,2	67,7									
			-10	116,0	53,3	109,5	58,0	102,7	63,1	95,4	68,6	86,3	74,6							
			-8	126,4	53,9	119,5	58,7	112,2	63,9	104,5	69,5	95,6	75,5	93,5	76,8					
			-4	148,0	55,2	140,4	60,1	132,3	65,4	123,6	71,2	114,2	77,4	112,4	78,7					
			0	172,3	56,5	163,9	61,6	154,9	67,1	145,0	73,0	134,3	79,4	132,3	80,7					
		Pure water	5	209,3	58,5	198,9	63,4	187,6	68,9	175,9	74,9	163,7	81,5	161,2	82,8					
			7	223,6	59,3	212,4	64,3	201,8	69,8	187,9	75,8	174,9	82,3	172,3	83,7					
			12	261,8	61,6	248,8	66,6	234,6	72,0	220,1	78,1	205,2	84,6	202,2	85,9					
15			286,7	63,2	272,3	68,1	256,7	73,6	241,0	79,6	224,9	86,1	221,7	87,5						
18			313,2	64,9	297,0	69,8	280,2	75,3	263,1	81,2	245,9	87,7	242,5	89,0						
900V		Glycol water	-12	126,6	61,0	120,2	66,8	113,3	73,2	105,8	80,3									
			-10	138,4	61,8	131,3	67,6	123,5	74,0	115,6	81,0									
			-8	150,4	62,6	141,6	68,6	134,1	74,8	125,8	81,9	116,6	89,6	114,7	91,3					
			-4	189,1	65,0	179,6	71,0	169,3	77,5	158,7	84,7	147,7	92,4	145,4	94,0					
			0	203,7	66,0	194,0	72,0	183,0	78,6	171,5	85,7	159,7	93,5	157,3	95,1					
		Pure water	5	249,5	69,0	236,9	75,1	223,4	81,6	209,3	88,9	194,9	96,8	192,0	98,4					
			7	266,6	70,3	252,6	76,3	239,8	83,0	223,2	90,2	208,0	98,0	204,7	99,7					
			12	311,3	73,6	294,7	79,6	277,9	86,3	260,0	93,7	242,9	101,5	239,3	103,0					
	15		339,7	75,8	321,9	81,9	303,3	88,6	284,5	95,9	265,4	103,7	261,6	105,3						
	18		369,8	78,2	350,1	84,4	330,1	91,1	309,5	98,4	289,3	106,1	285,3	107,7						
	1000V	Glycol water	-12	136,3	66,6	128,8	73,1	121,3	80,2	113,2	88,2									
			-10	149,0	67,5	140,7	73,8	132,4	81,0	123,7	89,0									
			-8	162,2	68,4	152,9	74,7	143,7	81,8	134,7	89,8	124,7	98,6	122,7	100,5					
			-4	189,8	70,3	179,2	76,6	168,5	83,7	157,7	91,7	146,8	100,5	144,6	102,4					
			0	220,5	72,6	208,8	78,9	196,6	86,1	183,9	94,0	171,3	102,8	168,8	104,6					
		Pure water	5	268,9	76,3	254,9	82,8	239,7	89,9	224,5	97,9	209,1	106,6	206,1	108,5					
			7	287,2	77,8	271,7	84,3	257,9	91,9	239,6	99,5	223,2	108,2	219,9	110,0					
			12	335,2	81,8	317,1	88,4	298,2	95,7	279,6	103,8	260,9	112,4	257,2	114,2					
15			365,9	84,4	345,9	91,1	325,4	98,5	305,1	106,7	285,2	115,2	281,4	117,0						
18			397,8	87,3	376,1	94,2	354,1	101,7	332,1	109,8	310,9	118,2	307,0	120,1						
1100V		Glycol water	-12	145,0	73,0	137,5	80,1	129,1	87,9	119,6	96,4									
			-10	159,6	74,1	150,7	81,2	141,5	89,0	131,6	97,5									
			-8	173,8	75,2	164,2	82,3	154,4	90,1	143,8	98,6	132,5	107,9							
			-4	203,6	77,5	192,9	84,7	181,2	92,5	169,4	101,1	157,0	110,4	154,3	112,3					
			0	237,0	80,2	224,5	87,4	211,5	95,3	197,9	104,0	183,6	113,2	181,0	115,3					
		Pure water	5	285,6	84,3	273,8	91,9	257,9	99,8	241,4	108,5	224,3	117,8	221,1	119,8					
			7	308,7	86,2	292,0	93,6	278,8	101,5	256,6	110,6	239,4	119,5	235,8	121,4					
			12	359,3	90,8	339,9	98,2	320,0	106,3	299,8	115,0	279,3	124,1	275,3	125,9					
	15		391,8	93,8	370,6	101,4	348,7	109,5	326,9	118,1	305,2	127,1								
	18		426,0	97,1	402,5	104,7	378,9	112,9	355,4	121,4										

Pf: Cooling capacity valid for delta T according to operating limits
 Pa: Power input
 Pc: Heating capacity valid for delta T according to operating limits

Mandatory glycol water utilization zone
 Calculation fouling factor 0,00005 m² °C/W
 EUROVENT conditions (EN 14511)

COOLING CAPACITIES

Reversible models

ILD ILDH ILDH	Evaporator water outlet temperature °C	INLET AIR TEMPERATURE AT THE CONDENSER °C										
		25		30		35		40		46		
		Pf kW	Pa kW	Pf kW	Pa kW	Pf kW	Pa kW	Pf kW	Pa kW	Pf kW	Pa kW	
80V	Glycol water	-10	11,8	5,0	11,0	5,5	10,1	6,2	9,1	6,9		
		-8	12,9	5,1	11,9	5,6	11,0	6,3	10,1	7,0		
		-4	15,0	5,2	14,0	5,8	13,0	6,4	12,0	7,1		
		0	17,3	5,4	16,3	6,0	15,2	6,6	14,0	7,3	12,6	8,3
	Pure water	5	20,9	5,7	19,7	6,3	18,4	6,9	17,1	7,6	15,5	8,6
		7	22,4	5,8	21,1	6,4	19,8	7,0	18,4	7,7	16,7	8,7
		12	25,9	6,1	24,5	6,7	23,0	7,3	21,4	8,0	19,6	9,0
		15	28,2	6,3	26,6	6,9	25,1	7,5	23,5	8,3	21,4	9,2
90V	Glycol water	-10	13,4	5,8	12,6	6,4	11,6	7,1	10,4	7,9		
		-8	14,6	5,9	13,7	6,5	12,7	7,2	11,5	8,0		
		-4	16,9	6,0	16,0	6,7	14,9	7,4	13,7	8,2		
		0	20,9	6,4	19,8	7,0	18,5	7,7	17,2	8,6	15,6	9,7
	Pure water	5	23,5	6,6	22,2	7,3	20,8	8,0	19,4	8,8	17,7	9,9
		7	25,0	6,8	23,8	7,4	22,3	8,2	20,8	9,0	19,0	10,0
		12	28,9	7,2	27,3	7,9	25,7	8,6	24,2	9,4	22,3	10,4
		15	31,3	7,5	29,6	8,2	27,9	8,9	26,2	9,7	24,3	10,7
100V	Glycol water	-10	15,9	6,6	14,8	7,4	13,7	8,2	12,4	9,1		
		-8	17,2	6,7	16,1	7,5	14,9	8,3	13,7	9,2		
		-4	20,0	6,9	18,8	7,7	17,5	8,5	16,2	9,4	14,3	10,7
		0	23,0	7,1	21,7	7,9	20,2	8,7	18,7	9,7	16,9	10,9
	Pure water	5	27,8	7,5	26,2	8,2	24,5	9,1	22,8	10,1	20,7	11,3
		7	29,6	7,6	28,0	8,4	26,2	9,3	24,4	10,2	22,1	11,4
		12	34,3	8,0	32,4	8,8	30,4	9,7	28,4	10,6	26,0	11,8
		15	37,2	8,3	35,2	9,1	33,0	10,0	30,9	10,9	28,3	12,1
120V	Glycol water	-10	17,7	7,8	16,5	8,6	15,3	9,5	13,9	10,6		
		-8	19,2	8,0	18,0	8,8	16,6	9,7	15,2	10,7		
		-4	22,3	8,2	20,9	9,0	19,5	10,0	17,9	11,0		
		0	25,6	8,5	24,0	9,3	22,4	10,3	20,8	11,3	18,7	12,6
	Pure water	5	30,7	8,9	28,9	9,8	27,1	10,7	25,2	11,7	22,9	13,0
		7	32,8	9,1	30,9	10,0	28,9	10,9	26,9	11,9	24,5	13,2
		12	37,8	9,6	35,7	10,5	33,5	11,4	31,2	12,4	28,6	13,7
		15	41,0	9,9	38,7	10,8	36,3	11,7	34,0	12,7	31,2	13,9
150V	Glycol water	-10	23,6	9,6	22,3	10,5	21,0	11,5	19,5	12,6		
		-8	25,4	9,7	24,1	10,7	22,7	11,7	21,1	12,8		
		-4	29,4	10,1	27,9	11,1	26,3	12,1	24,6	13,3	22,3	14,7
		0	33,6	10,5	31,9	11,5	30,1	12,6	28,2	13,8	25,8	15,3
	Pure water	5	40,3	11,1	38,2	12,2	36,0	13,3	33,9	14,6	31,1	16,1
		7	42,9	11,4	40,7	12,5	38,5	13,6	36,1	14,9	33,4	16,4
		12	49,4	12,0	46,9	13,1	44,3	14,3	41,7	15,6	38,8	17,1
		15	53,6	12,5	50,8	13,5	48,1	14,7	45,4	16,0	42,3	17,6
180V	Glycol water	-10	27,1	11,2	25,4	12,4	23,4	13,9	21,1	15,5		
		-8	29,3	11,4	27,6	12,6	25,6	14,0	23,3	15,6		
		-4	34,1	11,7	32,2	13,0	30,0	14,4	27,7	16,0	24,6	18,2
		0	39,2	12,1	37,1	13,4	34,8	14,8	32,3	16,4	29,1	18,6
	Pure water	5	47,1	12,9	44,6	14,2	42,0	15,6	39,3	17,2	35,9	19,2
		7	50,2	13,2	47,6	14,5	44,9	15,9	42,0	17,5	38,6	19,5
		12	57,9	14,1	54,9	15,4	51,8	16,8	48,7	18,3	45,0	20,3
		15	62,7	14,6	59,4	16,0	56,2	17,4	53,0	18,9	49,1	20,9

Pf: Cooling capacity valid for delta T according to operating limits
 Pa: Power input
 Pc: Heating capacity valid for delta T according to operating limits

Mandatory glycol water utilization zone
 Calculation fouling factor 0,00005 m² °C/W
 EUROVENT conditions (EN 14511)



Water chillers

COOLING CAPACITIES



Reversible models

ILD ILDC ILDH	Evaporator water outlet temperature °C	INLET AIR TEMPERATURE AT THE CONDENSER °C										
		25		30		35		40		46		
		Pf kW	Pa kW	Pf kW	Pa kW	Pf kW	Pa kW	Pf kW	Pa kW	Pf kW	Pa kW	
200V	Glycol water	-10	30,8	13,4	28,7	14,9	26,5	16,6	24,0	18,3		
		-8	33,4	13,6	31,2	15,1	29,0	16,8	26,5	18,6		
		-4	38,8	14,2	36,4	15,7	33,9	17,4	31,3	19,2		
		0	44,6	14,8	41,9	16,4	39,1	18,1	36,2	19,9	32,6	22,3
	Pure water	5	53,4	15,8	50,2	17,4	47,0	19,1	43,7	21,0	39,8	23,3
		7	56,9	16,2	53,6	17,8	50,2	19,6	46,8	21,4	42,7	23,7
		12	65,5	17,3	61,7	18,9	58,0	20,6	54,2	22,4	48,8	24,3
15	70,8	18,0	66,9	19,6	62,9	21,3	58,9	23,1	52,7	24,8		
240V	Glycol water	-10	35,7	15,4	33,2	17,0	30,7	18,8	27,8	20,8		
		-8	38,7	15,6	36,2	17,2	33,6	19,0	30,8	21,0		
		-4	45,3	16,0	42,6	17,6	39,7	19,4	36,7	21,4	32,6	24,1
		0	52,3	16,4	49,3	18,1	46,0	19,9	42,8	21,9	38,5	24,6
	Pure water	5	63,1	17,2	59,5	18,9	55,8	20,7	52,0	22,7	47,3	25,3
		7	67,5	17,6	63,8	19,2	59,9	21,1	55,8	23,0	50,9	25,6
		12	78,1	18,5	73,9	20,1	69,5	21,9	64,9	23,9	59,6	26,4
15	84,9	19,1	80,4	20,7	75,7	22,5	70,9	24,5	65,1	27,0		
300V	Glycol water	-10	44,6	19,9	42,2	21,7	39,6	23,7	36,4	25,8		
		-8	48,1	20,3	45,5	22,2	42,8	24,2	39,7	26,4		
		-4	55,5	21,2	52,6	23,2	49,6	25,4	46,2	27,6	41,9	30,4
		0	63,6	22,1	60,3	24,3	56,8	26,5	53,2	28,8	48,5	31,7
	Pure water	5	76,3	23,4	72,3	25,7	68,2	28,0	63,9	30,5	58,8	33,4
		7	81,4	24,0	77,1	26,3	72,8	28,7	68,2	31,1	63,0	34,1
		12	93,7	25,5	88,8	27,8	83,7	30,2	78,8	32,7	72,8	35,1
15	101,5	26,5	96,1	28,8	90,8	31,2	85,6	33,7	79,6	35,9		
350V	Glycol water	-10	52,4	22,9	49,5	25,0	46,4	27,3	42,9	30,1		
		-8	57,1	23,1	54,1	25,3	50,8	27,7	47,2	30,5		
		-4	67,1	23,9	63,5	26,1	59,8	28,6	55,8	31,3	50,6	35,0
		0	77,7	24,7	73,7	26,9	69,5	29,5	65,0	32,3	59,5	36,1
	Pure water	5	94,6	25,9	89,5	28,3	84,4	30,9	79,2	33,8	72,8	37,6
		7	101,4	26,5	96,0	28,8	90,5	31,5	85,0	34,4	78,5	38,3
		12	118,0	27,8	111,9	30,3	105,6	33,0	99,3	36,0	92,1	39,8
15	128,6	28,8	122,0	31,3	115,2	34,1	108,6	37,0	101,1	40,9		
18	139,6	30,0	132,2	32,5	124,9	35,3	118,1	38,3				
400V	Glycol water	-10	59,0	25,9	55,8	28,3	52,2	31,0	48,0	33,9		
		-8	64,3	26,2	60,9	28,8	57,1	31,5	52,9	34,4		
		-4	75,5	27,1	71,6	29,7	67,4	32,5	62,8	35,5	56,7	39,4
		0	87,3	28,0	83,0	30,7	78,3	33,6	73,2	36,7	66,8	40,7
	Pure water	5	105,8	29,5	100,6	32,3	94,9	35,3	89,0	38,5	81,5	42,5
		7	113,3	30,2	107,8	33,0	101,7	36,0	95,5	39,2	87,7	43,2
		12	131,7	31,8	125,1	34,6	118,2	37,7	111,1	40,9	102,5	44,9
15	143,3	32,9	136,2	35,7	128,7	38,7	121,1	42,0	112,1	46,0		
18	155,2	34,3	147,3	37,1	139,3	40,1	131,3	43,1				
500V	Glycol water	-10	72,6	33,1	68,3	36,2	63,7	39,6	58,3	43,3		
		-8	79,2	33,6	74,7	36,8	69,8	40,2	64,5	43,9		
		-4	92,8	34,8	87,9	38,0	82,5	41,5	76,7	45,3	68,8	50,2
		0	107,5	36,0	101,9	39,3	95,9	42,9	89,4	46,8	81,1	51,8
	Pure water	5	130,1	38,1	123,3	41,5	116,2	45,1	108,8	49,1	99,4	54,1
		7	139,4	39,0	132,1	42,4	124,6	46,1	116,7	50,0	106,9	55,0
		12	161,7	41,2	153,2	44,6	144,5	48,3	135,6	52,3	124,7	57,2
15	175,8	42,6	166,7	46,1	157,3	49,8	147,8	53,7	136,3	58,6		
18	190,6	44,1	180,6	47,6	170,6	51,3	160,5	55,2				

Pf: Cooling capacity valid for delta T according to operating limits
 Pa: Power input
 Pc: Heating capacity valid for delta T according to operating limits

Light blue box: Mandatory glycol water utilization zone
 Dark blue box: Calculation fouling factor 0,00005 m² °C/W
 Blue box: EUROVENT conditions (EN 14511)

AQUACIAT 2



COOLING CAPACITIES



Reversible models

ILD ILDC ILDH	Evaporator water outlet temperature °C	INLET AIR TEMPERATURE AT THE CONDENSER °C											
		25		30		35		40		46			
		Pf kW	Pa kW	Pf kW	Pa kW	Pf kW	Pa kW	Pf kW	Pa kW	Pf kW	Pa kW		
540V	Glycol water	-10	82,6	33,9	76,3	37,4	71,2	41,2	65,1	45,5			
		-8	88,1	34,3	83,1	37,8	77,7	41,6	71,8	45,9			
		-4	102,7	35,2	97,2	38,7	91,3	42,6	85,0	47,0			
		0	118,4	36,2	112,3	39,8	105,7	43,7	98,8	48,0	89,9	53,6	
	Pure water	5	142,7	37,8	135,5	41,5	127,8	45,5	119,8	49,9	109,8	55,6	
		7	153,1	38,6	145,4	42,3	137,2	46,3	128,7	50,7	118,1	56,4	
		12	177,8	40,5	168,8	44,2	159,5	48,3	149,9	52,7	138,2	58,4	
		15	193,4	41,8	183,7	45,5	173,8	49,6	163,5	54,0	151,2	59,7	
	600V	Glycol water	-10	90,5	37,7	85,8	41,4	80,7	45,2	74,5	49,6		
			-8	98,4	38,4	93,3	42,1	87,9	46,1	81,7	50,4		
			-4	113,8	39,7	108,2	43,6	102,1	47,8	95,6	52,3	86,9	58,1
			0	131,0	41,1	124,6	45,1	117,7	49,5	110,5	54,2	101,2	60,1
Pure water		5	157,8	43,3	150,1	47,5	142,0	52,1	133,4	56,9	122,8	63,1	
		7	168,8	44,2	160,7	48,5	151,9	53,1	142,9	58,0	131,8	64,2	
		12	195,7	46,6	186,1	50,9	176,1	55,6	165,9	60,5	153,6	66,9	
		15	212,7	48,2	202,3	52,5	191,5	57,2	180,6	62,2	167,8	68,6	
700V		Glycol water	18	228,1	49,6	218,1	54,1	206,8	58,6	195,8	63,8		
			-8	103,7	43,4	98,2	47,4	92,2	52,0				
			-4	118,9	44,9	113,2	49,2	106,6	53,9	99,6	58,8		
			0	137,8	47,0	129,3	51,4	121,0	55,7	113,3	60,9		
	Pure water	2	146,0	47,8	137,1	52,1	129,9	57,1	121,6	62,4	112,2	69,5	
		5	167,5	49,9	158,1	54,4	149,0	59,4	139,8	64,7	127,8	71,7	
		7	177,6	51,0	167,9	55,6	158,5	60,6	148,3	66,0	136,6	73,2	
		10	193,2	52,6	183,4	57,4	172,7	62,4	161,2	67,9			
	12	205,0	53,7	193,5	58,6	183,2	63,7						
	18	238,8	58,0	226,5	63,0	214,4	67,9						

Pf: Cooling capacity valid for delta T according to operating limits
 Pa: Power input
 Pc: Heating capacity valid for delta T according to operating limits

Mandatory glycol water utilization zone
 Calculation fouling factor 0,00005 m² °C/W
 EUROVENT conditions (EN 14511)



Water chillers

COOLING CAPACITIES



Reversible models

R410A	LOW NOISE - LN	ILD ILDH	Evaporator water outlet temperature °C	INLET AIR TEMPERATURE AT THE CONDENSER °C												
				25		30		35		40		45		46		
				Pf kW	Pa kW	Pf kW	Pa kW	Pf kW	Pa kW	Pf kW	Pa kW	Pf kW	Pa kW	Pf kW	Pa kW	
702V	Glycol water	-12	91,2	43,7	89,1	48,4	83,8	52,8	77,5	57,7						
		-10	103,1	45,0	97,5	49,0	91,6	53,5	85,4	58,5						
		-8	112,2	45,6	106,2	49,7	99,8	54,2	93,2	59,2	85,7	64,8	84,0	65,9		
		-4	131,5	46,8	124,7	51,0	117,3	55,6	109,7	60,8	101,7	66,4	100,1	67,6		
		0	150,2	47,9	142,5	52,2	134,4	56,9	125,8	62,2	117,0	68,0	115,1	69,2		
	Pure water	5	185,5	50,0	176,5	54,5	166,2	59,3	155,8	64,7	145,1	70,6	142,9	71,8		
		7	198,7	50,9	188,0	55,4	178,9	60,5	166,4	65,6	155,1	71,5	152,9	72,7		
		12	231,8	53,2	219,8	57,6	207,4	62,5	194,8	68,0	182,0	73,9	179,5	75,1		
		15	253,6	54,6	240,4	59,1	226,9	64,1	213,1	69,5	199,5	75,5	196,7	76,7		
		18	276,1	56,3	261,9	60,8	247,3	65,7	232,6	71,3	218,0	77,2	215,1	78,4		
800V	Glycol water	-12	104,5	50,7	98,6	55,3	92,1	60,3	84,7	65,7						
		-10	114,4	51,5	108,0	56,2	101,1	61,3	93,6	66,8						
		-8	124,4	52,2	117,6	57,0	110,3	62,2	102,5	67,8	93,4	73,9	91,7	75,1		
		-4	145,5	53,7	137,9	58,7	130,1	64,1	121,0	69,9	111,7	76,1	109,7	77,4		
		0	169,2	55,4	161,0	60,5	151,6	66,0	141,7	72,0	131,2	78,3	129,1	79,6		
	Pure water	5	202,1	57,7	191,6	62,8	180,8	68,5	169,4	74,6	157,5	81,0	155,1	82,4		
		7	215,2	58,7	204,4	63,8	196,3	69,4	181,0	75,7	168,4	82,1	165,9	83,4		
		12	251,4	61,2	238,6	66,5	225,3	72,2	211,6	78,3	197,2	84,8	194,4	86,2		
		15	274,5	63,1	260,7	68,2	246,1	73,9	231,2	80,0	215,7	86,6	212,9	87,9		
		18	298,9	65,0	283,5	70,2	268,0	75,8	251,8	81,8	235,5	88,3	232,3	89,6		
900V	Glycol water	-12	124,8	59,6	118,4	65,5	111,3	71,9	103,9	79,0						
		-10	136,3	60,5	129,0	66,4	121,3	72,9	113,5	79,9						
		-8	147,7	61,4	140,0	67,4	131,7	73,9	123,2	80,9	114,3	88,6				
		-4	172,0	63,3	163,2	69,4	153,6	75,9	144,0	83,0	133,8	90,8	131,7	92,4		
		0	199,5	65,5	189,4	71,7	178,5	78,4	167,1	85,6	155,3	93,4	153,1	95,1		
	Pure water	5	242,5	69,1	229,6	75,3	216,2	82,2	202,6	89,6	188,6	97,2	185,9	98,9		
		7	258,8	70,6	244,7	76,8	232,0	83,8	215,7	91,0	201,0	98,7	198,1	100,3		
		12	300,4	74,5	284,1	80,8	267,2	87,6	250,6	94,9	234,1	102,6	230,7	104,1		
		15	326,2	77,3	309,1	83,4	291,1	90,3	273,0	97,5	255,1	105,1	251,5	106,6		
		18	354,6	79,9	335,4	86,4	315,7	93,1	296,4	100,3	277,3	107,9	273,5	109,4		
1000V	Glycol water	-12	134,0	65,5	126,8	72,0	119,1	79,3	110,9	87,3						
		-10	146,2	66,5	138,2	73,0	129,9	80,3	121,2	88,3						
		-8	158,6	67,6	149,9	74,0	140,9	81,3	131,8	89,3	121,8	98,1				
		-4	185,3	69,9	175,0	76,4	164,6	83,6	154,0	91,7	143,0	100,5	140,9	102,4		
		0	214,5	72,5	203,0	79,1	190,9	86,4	178,7	94,5	166,4	103,3	163,9	105,2		
	Pure water	5	260,6	76,9	246,1	83,7	231,7	91,1	216,8	99,1	202,1	107,8	199,2	109,6		
		7	277,5	78,6	262,2	85,4	248,5	93,3	231,0	101,0	215,4	109,5	212,4	111,3		
		12	322,1	83,4	304,2	90,3	286,2	97,8	268,3	105,8	250,8	114,3	247,5	116,2		
		15	350,4	86,6	330,8	93,6	311,5	101,1	292,2	109,1	273,6	117,6	269,9	119,3		
		18	379,7	90,0	358,7	97,1	337,9	104,7	317,1	112,7	297,5	121,0	293,8	122,7		
1100V	Glycol water	-12	142,7	72,2	135,1	79,4	126,5	87,3								
		-10	156,7	73,6	147,5	80,7	138,3	88,5	128,5	97,1						
		-8	170,0	74,8	160,7	82,0	150,6	89,9	140,2	98,5	129,1	107,8				
		-4	198,8	77,6	188,0	84,9	176,5	92,9	164,7	101,6	152,3	110,8	149,7	112,7		
		0	230,4	80,7	218,3	88,3	205,1	96,3	191,6	105,0	177,7	114,3	174,9	116,2		
	Pure water	5	280,0	86,1	264,2	93,6	248,5	101,7	232,3	110,3	216,2	119,5	213,0	121,3		
		7	297,6	88,0	281,0	95,6	267,7	103,6	247,3	112,3	230,3	121,4	226,8	123,2		
		12	344,3	93,5	325,3	101,1	306,2	109,2	286,7	117,8	267,2	126,6				
		15	374,1	97,0	353,7	104,7	332,5	112,8	311,6	121,3						
		18	405,1	100,9	382,3	108,6	360,0	116,7	337,7	125,0						

Pf: Cooling capacity valid for delta T according to operating limits
 Pa: Power input
 Pc: Heating capacity valid for delta T according to operating limits

Mandatory glycol water utilization zone
 Calculation fouling factor 0,00005 m² °C/W
 EUROVENT conditions (EN 14511)

HEATING CAPACITIES



Reversible models

ILD ILDC ILDH	External air temperature in °C WB (1)	CONDENSER WATER OUTLET TEMPERATURE IN °C										
		30		35		40		45		50		
		Pc kW	Pa kW	Pc kW	Pa kW	Pc kW	Pa kW	Pc kW	Pa kW	Pc kW	Pa kW	
80V	Pure water	-12	13,1	5,0	13,0	5,6	12,8	6,3				
		-10	14,0	5,0	13,8	5,6	13,7	6,3				
		-5	16,1	5,0	15,9	5,6	15,7	6,3	15,5	7,0		
		0	18,5	5,0	18,2	5,6	17,9	6,3	17,6	7,0	17,3	7,9
		5	20,9	5,0	20,5	5,7	20,1	6,3	19,7	7,0	19,4	7,9
		7	21,9	5,1	21,5	5,7	21,1	6,3	20,7	7,0	20,2	7,9
		10	23,6	5,1	23,1	5,7	22,6	6,4	22,1	7,0	21,6	7,9
		15	26,5	5,1	25,9	5,8	25,3	6,4	24,7	7,1	24,0	7,9
20	29,4	5,2	28,8	5,8	28,0	6,4	27,3	7,1	26,5	7,9		
90V	Pure water	-12	14,7	5,6	14,6	6,3	14,4	7,0				
		-10	15,7	5,6	15,5	6,3	15,3	7,0				
		-5	18,0	5,7	17,8	6,3	17,6	7,0	17,3	7,9		
		0	20,5	5,7	20,3	6,3	20,0	7,0	19,8	7,9	19,4	8,8
		5	23,3	5,7	22,9	6,4	22,5	7,1	22,2	7,9	21,8	8,8
		7	24,3	5,7	24,0	6,4	23,6	7,1	23,2	7,9	22,8	8,8
		10	26,2	5,7	25,7	6,4	25,3	7,1	24,8	7,9	24,3	8,8
		15	29,3	5,8	28,7	6,4	28,2	7,1	27,6	7,9	27,0	8,8
20	32,6	5,9	31,9	6,5	31,1	7,2	30,4	8,0	29,7	8,8		
100V	Pure water	-12	18,0	6,8	17,8	7,6	17,4	8,4				
		-10	19,2	6,8	19,0	7,6	18,6	8,4				
		-5	22,1	6,9	21,7	7,6	21,4	8,5	21,0	9,4	20,5	10,6
		0	25,2	7,0	24,8	7,7	24,4	8,6	24,0	9,5	23,5	10,7
		5	28,5	7,0	28,0	7,7	27,4	8,6	26,9	9,6	26,3	10,7
		7	29,9	7,0	29,3	7,7	28,7	8,6	28,1	9,6	27,5	10,7
		10	32,1	7,0	31,5	7,8	30,8	8,6	30,1	9,6	29,4	10,7
		15	36,0	7,1	35,2	7,8	34,4	8,7	33,5	9,6	32,6	10,7
20	39,9	7,1	39,0	7,9	38,0	8,7	37,0	9,6	35,9	10,7		
120V	Pure water	-12	20,5	7,8	20,2	8,6	20,0	9,5				
		-10	21,8	7,8	21,5	8,6	21,1	9,5				
		-5	24,9	7,8	24,6	8,6	24,2	9,5	23,5	10,6	23,1	11,8
		0	28,5	7,9	28,0	8,7	27,5	9,6	27,0	10,6	25,9	11,8
		5	32,1	7,9	31,5	8,7	30,9	9,6	30,2	10,7	29,6	11,8
		7	33,7	7,9	33,0	8,8	32,3	9,7	31,6	10,7	30,9	11,8
		10	36,1	8,0	35,4	8,8	34,6	9,7	33,8	10,7	33,0	11,8
		15	40,4	8,0	39,5	8,8	38,6	9,7	37,6	10,7	36,5	11,8
20	44,7	8,1	43,7	8,9	42,6	9,7	41,7	10,7	40,2	11,9		
150V	Pure water	-12	26,8	9,5	26,5	10,4						
		-10	28,4	9,6	28,1	10,5	27,6	11,7				
		-5	32,4	9,8	32,1	10,8	31,7	11,9	30,9	12,9		
		0	36,8	10,0	36,4	11,0	36,0	12,1	35,4	13,3	34,1	14,4
		5	41,5	10,1	41,0	11,1	40,4	12,2	39,6	13,5	38,8	14,8
		7	43,5	10,2	42,8	11,1	42,1	12,3	41,4	13,6	40,5	14,9
		10	46,7	10,2	45,9	11,2	45,2	12,4	44,3	13,7	43,3	15,0
		15	52,2	10,3	51,2	11,3	50,2	12,5	49,1	13,8	47,9	15,2
20	57,8	10,4	56,7	11,4	55,4	12,6	54,1	13,9	52,7	15,3		
180V	Pure water	-12	30,7	11,1	30,4	12,4	30,1	13,9				
		-10	32,8	11,1	32,5	12,4	32,0	13,9	31,3	15,7	30,5	17,6
		-5	37,6	11,1	37,2	12,4	36,7	13,9	36,1	15,6	35,4	17,5
		0	42,9	11,2	42,4	12,4	41,8	13,8	41,2	15,5	40,4	17,4
		5	48,6	11,2	47,9	12,4	47,1	13,8	46,3	15,4	45,4	17,3
		7	50,7	11,2	50,2	12,4	49,3	13,8	48,4	15,4	47,5	17,3
		10	54,8	11,3	54,0	12,5	52,8	13,8	51,9	15,4	50,8	17,2
		15	61,5	11,4	60,3	12,6	59,0	13,9	57,7	15,5	56,4	17,2
20	68,4	11,5	66,9	12,7	65,3	14,1	63,8	15,6	62,1	17,3		

Pf: Cooling capacity valid for delta T according to operating limits
 Pa: Power input
 Pc: Heating capacity valid for delta T according to operating limits

Calculation fouling factor 0,00005 m² °C/W
 EUROVENT conditions (EN 14511)

(1) Variation of relative humidity for following calculation:
 -20°C 95%HR / +7°C 85 %HR / +27°C 50%HR



Water chillers

HEATING CAPACITIES



Reversible models

ILD ILDC ILDH	External air temperature in °C WB (1)	CONDENSER WATER OUTLET TEMPERATURE IN °C										
		30		35		40		45		50		
		Pc kW	Pa kW	Pc kW	Pa kW	Pc kW	Pa kW	Pc kW	Pa kW	Pc kW	Pa kW	
200V	Pure water	-12	34,8	12,7	34,3	14,3	33,9	16,0				
		-10	37,3	12,7	36,9	14,3	36,1	16,0	35,7	18,0		
		-5	42,8	12,7	42,3	14,3	41,8	16,0	40,8	17,9	39,8	20,1
		0	48,8	12,7	48,2	14,3	47,5	16,0	46,5	17,9	44,8	20,1
		5	55,2	12,8	54,4	14,3	53,5	16,0	52,5	17,9	51,6	20,1
		7	57,9	12,8	56,9	14,3	55,9	16,0	54,9	17,9	53,9	20,1
		10	62,1	12,8	61,0	14,3	60,0	16,0	58,8	17,9	57,5	20,1
		15	69,5	12,9	68,3	14,4	66,9	16,0	65,4	17,9	63,9	20,0
		20	77,3	13,1	75,7	14,5	74,1	16,1	72,3	17,9	70,4	20,0
240V	Pure water	-12	41,1	15,6	40,7	17,2						
		-10	43,5	15,6	43,3	17,2	42,7	19,0				
		-5	50,3	15,6	49,5	17,2	48,7	19,0	48,0	21,0		
		0	57,3	15,5	56,4	17,1	55,4	18,9	54,4	21,0	53,4	23,4
		5	64,7	15,5	63,5	17,1	62,3	18,9	60,9	20,9	59,6	23,3
		7	67,9	15,5	66,5	17,1	65,2	18,9	63,7	20,9	62,3	23,3
		10	72,9	15,5	71,4	17,1	69,8	18,9	68,2	20,9	66,5	23,2
		15	81,4	15,6	79,7	17,2	77,9	18,9	75,9	20,9	73,8	23,2
		20	90,1	15,8	88,3	17,3	86,0	19,0	83,7	20,9	81,2	23,1
300V	Pure water	-12	52,5	18,8	52,0	20,5	51,4	22,5				
		-10	55,7	18,9	55,3	20,7	54,1	22,6				
		-5	63,6	19,2	63,1	21,1	62,4	23,2	60,3	25,4	58,0	27,9
		0	72,2	19,4	71,5	21,3	70,7	23,5	69,3	25,9	66,5	28,4
		5	81,2	19,5	80,4	21,5	79,2	23,8	78,0	26,2	76,6	29,0
		7	85,2	19,6	83,9	21,6	82,8	23,9	81,4	26,3	79,9	29,1
		10	91,0	19,6	89,7	21,7	88,4	24,0	87,1	26,5	85,3	29,2
		15	101,8	19,8	100,2	21,8	98,5	24,1	96,5	26,7	94,4	29,5
		20	112,7	20,1	110,7	22,0	108,6	24,2	106,1	26,8	103,6	29,6
350V	Pure water	-12	63,0	23,1	62,1	25,2						
		-10	64,7	23,2	64,2	25,3	63,6	27,7				
		-5	74,2	23,4	73,4	25,5	72,4	28,0	71,6	30,8		
		0	84,8	23,6	83,6	25,7	82,3	28,2	81,0	31,0	79,8	34,2
		5	95,9	23,8	94,3	25,9	92,6	28,4	90,9	31,3	89,1	34,5
		7	100,6	23,9	98,7	26,0	96,8	28,5	95,0	31,4	93,1	34,6
		10	108,1	24,0	106,2	26,2	103,9	28,7	101,6	31,5	99,5	34,8
		15	121,1	24,3	118,6	26,5	115,9	28,9	113,0	31,8	110,4	35,0
		20	134,2	24,6	130,9	26,7	127,9	29,2	124,7	32,0	121,6	35,3
400V	Pure water	-12	69,3	26,3	68,5	28,8	68,0	31,5				
		-10	73,5	26,4	73,1	28,9	72,2	31,6	71,1	34,7		
		-5	84,5	26,7	83,8	29,2	82,7	32,0	81,5	35,1		
		0	96,6	26,9	95,4	29,5	94,3	32,4	92,7	35,5	90,9	39,0
		5	109,0	27,2	107,7	29,8	105,9	32,7	104,0	35,9	101,9	39,5
		7	114,3	27,3	112,6	29,9	110,7	32,8	108,8	36,0	106,4	39,6
		10	122,7	27,5	120,9	30,1	118,8	33,0	116,4	36,2	113,8	39,8
		15	137,3	27,8	135,0	30,3	132,2	33,2	129,3	36,5	126,3	40,1
		20	152,3	28,2	149,5	30,7	145,9	33,5	142,4	36,7	138,8	40,4
500V	Pure water	-12	84,4	31,5	83,4	34,6	82,4	37,9				
		-10	89,7	31,6	88,8	34,7	87,7	38,1	86,2	42,0		
		-5	103,1	31,8	101,9	34,9	100,6	38,4	99,1	42,3	97,0	46,7
		0	117,6	32,1	116,3	35,2	114,7	38,7	112,9	42,6	110,7	47,1
		5	132,9	32,4	131,2	35,5	129,1	39,0	126,9	43,0	124,3	47,4
		7	139,2	32,6	137,3	35,6	135,1	39,2	132,6	43,1	129,8	47,6
		10	149,5	32,8	147,3	35,9	144,7	39,4	142,1	43,4	139,0	47,7
		15	167,7	33,2	164,8	36,3	161,5	39,8	157,9	43,7	153,9	48,1
		20	186,0	33,7	182,1	36,7	177,8	40,1	173,6	44,0	169,2	48,4

Pf: Cooling capacity valid for delta T according to operating limits
 Pa: Power input
 Pc: Heating capacity valid for delta T according to operating limits

Calculation fouling factor 0,00005 m² °C/W
 EUROVENT conditions (EN 14511)

(1) Variation of relative humidity for following calculation:
 -20°C 95%HR / +7°C 85 %HR / +27°C 50%HR

HEATING CAPACITIES

Reversible models

R410A	HIGH PERFORMANCES - HP	ILD ILDC ILDH	External air temperature in °C WB (1)	CONDENSER WATER OUTLET TEMPERATURE IN °C																		
				30		35		40		45		50										
				Pc kW	Pa kW	Pc kW	Pa kW	Pc kW	Pa kW	Pc kW	Pa kW	Pc kW	Pa kW									
540V	Pure water		-12	95,4	34,5	94,8	38,0	94,0	42,0													
			-10	99,3	34,6	98,9	38,1	98,3	42,1													
			-5	114,8	35,0	113,7	38,5	113,0	42,4	111,0	46,8	108,6	52,0									
			0	128,7	35,1	127,1	38,7	125,3	42,7	123,5	47,2	121,6	52,2									
			5	147,8	35,4	145,8	39,0	143,5	43,1	140,8	47,6	137,9	52,6									
			7	155,2	35,5	152,8	39,1	150,0	43,2	147,1	47,7	144,0	52,7									
			10	166,2	35,7	163,7	39,3	160,6	43,3	157,3	47,9	153,7	52,9									
			15	185,7	36,0	182,6	39,6	178,8	43,6	174,5	48,1	170,1	53,2									
			20	205,7	36,5	201,5	39,9	196,8	43,9	191,9	48,4	186,7	53,4									
			-12	105,7	38,4	104,8	42,2	103,6	46,4													
			-10	110,5	38,5	109,3	42,3	107,9	46,6	106,2	51,0											
			-5	127,0	38,8	125,5	42,7	124,0	47,0	122,1	51,4	119,7	57,2									
			0	146,0	39,0	144,3	43,0	142,5	47,5	140,4	52,1	137,8	57,7									
			5	163,9	39,3	162,2	43,4	159,7	47,9	157,1	52,8	154,0	58,1									
7	171,7	39,5	169,3	43,5	166,9	48,0	164,0	53,0	160,8	58,4												
10	183,9	39,7	181,3	43,7	178,6	48,3	175,3	53,3	171,5	58,8												
15	205,6	40,1	202,2	44,1	198,6	48,6	194,4	53,7	189,8	59,3												
20	227,7	40,7	223,4	44,5	218,6	49,0	213,5	54,1	208,1	59,7												
700V	Pure water		-10	122,6	41,2	122,9	45,1															
			-5	140,6	41,9	141,0	46,0	138,9	50,1													
			0	158,7	42,5	159,1	46,8	158,0	51,1	156,2	56,4	154,5	62,0									
			2	169,6	42,9	167,5	46,9	165,3	51,4	163,4	56,5	161,4	62,2									
			5	181,6	43,2	178,7	47,2	176,4	51,7	174,2	56,8	172,0	62,5									
			7	190,0	43,6	186,8	47,4	184,0	52,0	181,5	57,1	178,8	62,6									
			10	203,1	43,9	199,6	47,9	196,5	52,4	193,6	57,5	190,6	63,2									
			15	226,9	44,7	222,1	48,9	218,2	53,3	214,0	58,5	209,8	64,0									
20	251,0	45,7	245,3	49,5	240,2	54,1	235,1	59,1	229,9	64,8												

Pf: Cooling capacity valid for delta T according to operating limits
 Pa: Power input
 Pc: Heating capacity valid for delta T according to operating limits

Calculation fouling factor 0,00005 m² °C/W
 EUROVENT conditions (EN 14511)
 (1) Variation of relative humidity for following calculation:
 -20°C 95%HR / +7°C 85 %HR / +27°C 50%HR

HEATING CAPACITIES



Reversible models

ILD ILDC ILDH	External air temperature in °C WB (1)	CONDENSER WATER OUTLET TEMPERATURE IN °C										
		30		35		40		45		50		
		Pc kW	Pa kW	Pc kW	Pa kW	Pc kW	Pa kW	Pc kW	Pa kW	Pc kW	Pa kW	
702V	Pure water	-12	114,7	45,8	121,4	50,0	120,0	54,4	118,7	59,4		
		-10	130,0	46,4	128,4	50,3	126,7	54,8	125,4	59,8		
		-5	148,9	47,2	146,9	51,1	144,6	55,7	142,4	60,8	140,5	66,6
		0	170,6	47,8	167,5	51,9	164,4	56,6	161,4	61,9	158,3	67,8
		5	193,2	48,4	189,2	52,6	185,3	57,3	181,1	62,6	177,1	68,7
		7	202,8	48,7	198,4	52,8	194,3	57,5	191,1	63,2	185,4	69,0
		10	218,6	49,1	213,7	53,2	208,6	57,9	203,4	63,3	198,2	69,4
		15	246,0	49,8	239,7	53,9	233,3	58,6	226,9	63,9	220,5	70,0
		20	273,7	50,5	266,5	54,5	258,9	59,2	251,2	64,6	243,3	70,6
800V	Pure water	-12	136,0	52,0	134,6	56,6	133,0	61,6	131,0	67,2		
		-10	144,1	52,3	142,4	57,0	140,6	62,1	138,8	67,7		
		-5	165,0	53,3	163,1	58,1	160,8	63,4	158,3	69,2	155,6	75,6
		0	188,5	54,1	185,9	59,0	183,0	64,5	179,7	70,6	176,0	77,1
		5	213,5	54,8	209,7	59,8	206,0	65,3	201,7	71,5	197,1	78,2
		7	223,5	55,0	220,8	61,8	215,6	65,6	213,5	71,5	206,2	78,6
		10	240,5	55,5	236,0	60,4	231,2	66,0	226,2	72,2	220,5	79,1
		15	270,2	56,2	264,1	61,1	258,3	66,6	251,8	72,9	244,8	79,7
		20	300,4	57,1	293,0	61,8	285,8	67,3	277,8	73,4	269,5	80,3
900V	Pure water	-12	160,8	60,0	159,7	65,8	159,0	72,2				
		-10	169,7	60,4	168,4	66,2	167,1	72,6	166,0	79,8		
		-5	193,8	61,3	191,6	67,2	189,4	73,7	187,1	80,9	185,2	89,0
		0	221,0	62,2	217,6	68,1	214,3	74,6	210,8	82,0	207,5	90,1
		5	250,3	62,6	245,5	68,4	240,7	75,0	235,9	82,3	231,1	90,4
		7	262,4	62,9	257,1	68,7	252,0	75,2	247,9	82,7	241,5	90,8
		10	282,1	63,4	276,3	69,2	270,1	75,7	263,9	83,0	257,6	91,2
		15	316,9	64,3	309,4	69,9	301,5	76,4	293,7	83,8	285,5	91,9
		20	352,5	65,2	343,2	70,8	333,8	77,2	324,0	84,5	314,3	92,7
1000V	Pure water	-12	171,3	64,9	170,6	71,1	169,9	78,3				
		-10	181,2	65,0	179,8	71,4	178,6	78,5	177,7	86,7		
		-5	207,4	66,0	204,7	72,3	202,3	79,4	200,3	87,4	198,4	96,6
		0	236,7	67,1	232,7	73,3	228,9	80,3	225,4	88,4	222,3	97,6
		5	268,0	68,0	262,4	74,2	257,2	81,3	252,2	89,4	247,4	98,5
		7	281,1	68,4	274,9	74,6	269,0	81,6	265,2	89,9	258,1	98,7
		10	302,1	69,0	295,5	75,1	288,6	82,1	281,9	90,1	275,6	99,2
		15	339,8	70,0	330,9	76,1	322,5	83,1	314,0	91,0	305,8	100,0
		20	379,0	71,1	367,7	77,1	357,4	84,1	347,0	92,1	336,4	101,0
1100V	Pure water	-12	183,2	70,4	182,3	77,4	181,6	85,2				
		-10	193,6	70,8	192,2	77,8	191,0	85,6				
		-5	221,8	71,9	219,0	78,9	216,8	86,8	214,6	95,5	212,4	105,3
		0	253,2	73,0	249,4	80,0	245,9	87,9	241,7	96,7	238,3	106,5
		5	286,4	73,5	281,2	80,5	276,3	88,3	271,3	97,1	265,6	106,9
		7	300,3	73,9	294,6	80,9	288,9	88,7	285,7	97,1	277,5	107,3
		10	322,6	74,6	316,1	81,5	309,6	89,3	302,8	98,0	296,0	107,8
		15	362,4	75,6	354,0	82,5	345,6	90,2	336,8	98,9	328,0	108,6
		20	402,7	76,7	392,8	83,5	382,3	91,2	371,9	99,9	360,9	109,6

R410A

HAUTE PERFORMANCE - HP

AQUACIAT 2

Pf: Cooling capacity valid for delta T according to operating limits
 Pa: Power input
 Pc: Heating capacity valid for delta T according to operating limits

Calculation fouling factor 0,00005 m² °C/W
 EUROVENT conditions (EN 14511)

(1) Variation of relative humidity for following calculation:
 -20°C 95%HR / +7°C 85 %HR / +27°C 50%HR

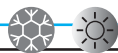

Reversible models

ILD ILDH	External air temperature in °C WB (1)	CONDENSER WATER OUTLET TEMPERATURE IN °C										
		30		35		40		45		50		
		Pc kW	Pa kW	Pc kW	Pa kW	Pc kW	Pa kW	Pc kW	Pa kW	Pc kW	Pa kW	
80V	Pure water	-12	12,9	4,9	12,8	5,5	12,7	6,1				
		-10	13,8	4,9	13,6	5,5	13,5	6,1				
		-5	15,8	4,9	15,6	5,5	15,4	6,1	15,3	6,9		
		0	18,1	4,9	17,8	5,5	17,6	6,1	17,3	6,9	17,1	7,7
		5	20,5	4,9	20,2	5,5	19,8	6,1	19,4	6,9	19,1	7,7
		7	21,5	4,9	21,1	5,5	20,7	6,1	20,3	6,9	20,0	7,7
		10	23,1	5,0	22,7	5,5	22,3	6,1	21,8	6,9	21,3	7,7
		15	25,9	5,0	25,4	5,6	24,8	6,2	24,3	6,9	24,0	7,7
		20	28,8	5,0	28,2	5,6	27,5	6,2	26,8	6,9	26,1	7,7
90V	Pure water	-12	14,4	5,5	14,3	6,1						
		-10	15,4	5,5	15,3	6,1	15,1	6,9				
		-5	17,6	5,5	17,5	6,1	17,3	6,9	17,1	7,7		
		0	20,1	5,5	19,9	6,2	19,7	6,9	19,4	7,7	19,1	8,7
		5	22,6	5,6	22,4	6,2	22,1	6,9	21,8	7,7	21,5	8,7
		7	23,8	5,6	23,5	6,2	23,2	6,9	22,8	7,7	22,4	8,7
		10	25,5	5,6	25,2	6,2	24,8	6,9	24,4	7,7	24,0	8,7
		15	28,7	5,6	28,2	6,2	27,6	7,0	27,1	7,7	26,6	8,6
		20	31,9	5,7	31,2	6,3	30,5	7,0	29,9	7,8	29,2	8,7
100V	Pure water	-12	17,3	6,4	17,2	7,2						
		-10	18,5	6,4	18,4	7,2	18,2	8,0				
		-5	21,2	6,4	21,0	7,3	20,7	8,1	20,5	9,1		
		0	24,2	6,5	23,9	7,3	23,5	8,2	23,2	9,2	22,9	10,3
		5	27,3	6,5	26,9	7,3	26,5	8,2	26,0	9,2	25,6	10,3
		7	28,7	6,5	28,2	7,4	27,7	8,2	27,2	9,2	26,7	10,3
		10	30,7	6,6	30,2	7,4	29,6	8,2	29,1	9,2	28,5	10,3
		15	34,4	6,6	33,8	7,4	33,1	8,2	32,4	9,2	31,6	10,3
		20	38,2	6,6	37,4	7,4	36,6	8,3	35,7	9,2	34,8	10,3
120V	Pure water	-12	19,6	7,4	19,4	8,2	19,3	9,1				
		-10	21,0	7,4	20,8	8,2	20,6	9,1				
		-5	24,0	7,4	23,7	8,2	23,4	9,2	23,1	10,2		
		0	27,3	7,4	26,9	8,3	26,5	9,2	26,1	10,2	25,7	11,4
		5	30,8	7,5	30,3	8,3	29,8	9,3	29,2	10,3	28,7	11,4
		7	32,2	7,5	31,7	8,3	31,1	9,3	30,5	10,3	29,9	11,4
		10	34,5	7,5	33,9	8,4	33,2	9,3	32,6	10,3	31,9	11,4
		15	38,6	7,6	37,9	8,4	37,1	9,3	36,3	10,3	35,4	11,5
		20	42,8	7,7	41,9	8,4	41,0	9,3	39,9	10,3	38,9	11,5
150V	Pure water	-12	25,5	9,0	25,3	9,9						
		-10	27,2	9,1	26,9	10,0	26,7	11,0				
		-5	30,9	9,3	30,7	10,3	30,4	11,3	30,0	12,4		
		0	35,1	9,5	34,8	10,5	34,4	11,6	34,0	12,8	33,5	14,1
		5	39,4	9,6	39,1	10,6	38,6	11,7	38,1	13,0	37,4	14,3
		7	41,3	9,7	40,9	10,7	40,3	11,8	39,8	13,1	39,1	14,4
		10	44,1	9,7	43,6	10,7	43,1	11,9	42,4	13,2	41,6	14,5
		15	49,4	9,8	48,7	10,8	47,9	12,0	47,1	13,3	46,1	14,7
		20	54,8	9,9	53,7	10,9	52,8	12,0	51,8	13,4	50,6	14,8
180V	Pure water	-12	29,3	10,7	29,0	12,0						
		-10	30,7	10,7	30,4	12,0	30,2	13,4				
		-5	34,6	10,7	34,4	12,0	34,0	13,4	33,8	15,1		
		0	38,9	10,7	38,5	12,0	38,2	13,4	37,7	15,1	37,4	16,8
		5	46,0	10,7	45,5	12,0	44,9	13,4	44,3	15,0	43,7	16,8
		7	48,4	10,8	47,7	12,0	47,1	13,4	46,3	15,0	45,7	16,8
		10	51,7	10,8	51,0	12,0	50,3	13,4	49,5	15,0	48,8	16,8
		15	58,0	10,9	57,1	12,1	56,2	13,4	55,1	15,0	54,1	16,9
		20	64,5	11,0	63,3	12,2	62,1	13,5	60,8	15,1	59,6	16,9

Pf: Cooling capacity valid for delta T according to operating limits
 Pa: Power input
 Pc: Heating capacity valid for delta T according to operating limits

Calculation fouling factor 0,00005 m² °C/W
 EUROVENT conditions (EN 14511)

(1) Variation of relative humidity for following calculation:
 -20°C 95%HR / +7°C 85 %HR / +27°C 50%HR

HEATING CAPACITIES



Reversible models

ILD ILDC ILDH	External air temperature in °C WB (1)	CONDENSER WATER OUTLET TEMPERATURE IN °C										
		30		35		40		45		50		
		Pc kW	Pa kW	Pc kW	Pa kW	Pc kW	Pa kW	Pc kW	Pa kW	Pc kW	Pa kW	
200V	Pure water	-12	32,9	12,3	32,8	13,9	32,6	15,6				
		-10	35,5	12,3	35,2	13,8	35,0	15,6	34,6	17,6		
		-5	40,4	12,3	40,1	13,8	39,9	15,6	39,6	17,6		
		0	46,1	12,3	45,6	13,8	45,2	15,5	44,8	17,5	44,3	19,7
		5	52,0	12,3	51,4	13,8	50,8	15,5	50,1	17,5	49,5	19,7
		7	54,5	12,4	53,8	13,8	53,1	15,5	52,4	17,5	51,6	19,7
		10	58,4	12,4	57,6	13,9	56,7	15,6	55,8	17,5	55,0	19,7
		15	65,2	12,4	64,3	13,9	63,3	15,6	62,1	17,5	61,0	19,6
		20	72,4	12,5	71,2	14,0	69,9	15,6	68,6	17,5	67,1	19,6
240V	Pure water	-12	40,0	15,0	39,7	16,7						
		-10	42,8	15,0	42,3	16,7	41,8	18,6				
		-5	48,9	15,0	48,3	16,7	47,7	18,5	47,0	20,6		
		0	55,8	15,0	55,0	16,6	54,1	18,5	53,2	20,6	52,3	22,9
		5	62,9	15,0	61,8	16,6	60,8	18,4	59,6	20,5	58,5	22,8
		7	65,9	15,1	64,7	16,6	63,5	18,4	62,3	20,5	61,0	22,8
		10	70,6	15,1	69,3	16,6	68,0	18,4	66,6	20,5	65,1	22,8
		15	78,9	15,2	77,6	16,7	75,8	18,5	74,1	20,5	72,2	22,7
		20	87,5	15,3	85,7	16,8	83,8	18,5	81,7	20,5	79,4	22,7
300V	Pure water	-12	50,4	18,2	49,9	19,8	49,2	21,9				
		-10	53,9	18,4	53,6	20,1	53,1	22,1				
		-5	61,4	18,6	61,1	20,5	60,5	22,5	59,8	24,8	58,6	27,4
		0	69,6	18,8	69,1	20,8	68,5	23,0	67,7	25,3	66,7	27,9
		5	78,3	18,9	77,5	21,0	76,8	23,2	75,7	25,7	74,6	28,3
		7	82,0	19,0	81,1	21,0	80,1	23,3	79,1	25,8	77,8	28,4
		10	87,6	19,1	86,5	21,1	85,5	23,4	84,2	25,9	82,8	28,7
		15	97,7	19,2	96,5	21,3	95,1	23,5	93,4	26,1	91,7	28,9
		20	108,3	19,5	106,6	21,4	104,9	23,7	102,7	26,3	100,5	29,1
350V	Pure water	-12	59,5	22,1	59,0	24,2						
		-10	63,5	22,1	62,9	24,2	62,3	26,6				
		-5	72,4	22,3	71,7	24,4	70,9	26,8	70,2	29,6	68,9	32,8
		0	82,6	22,4	81,5	24,6	80,5	27,1	79,4	29,9	78,3	33,1
		5	93,6	22,6	91,8	24,8	90,5	27,3	88,9	30,1	87,4	33,4
		7	97,9	22,7	96,2	24,9	94,5	27,4	92,9	30,2	91,2	33,5
		10	104,8	22,9	103,0	25,0	101,2	27,5	99,4	30,4	97,5	33,6
		15	117,6	23,1	115,3	25,3	112,9	27,8	110,5	30,6	108,1	33,9
		20	130,5	23,4	127,7	25,5	124,8	28,0	121,9	30,9	118,8	34,1
400V	Pure water	-12	67,8	25,0	66,9	27,4	66,3	30,1				
		-10	72,1	25,1	71,6	27,6	70,8	30,3				
		-5	82,5	25,3	81,8	27,9	80,9	30,7	79,9	33,7	78,4	37,2
		0	94,0	25,6	93,2	28,2	92,1	31,0	90,8	34,2	89,2	37,7
		5	106,1	25,8	105,0	28,4	103,4	31,3	101,8	34,6	99,9	38,1
		7	111,5	25,9	109,9	28,5	108,0	31,4	106,4	34,7	104,3	38,3
		10	119,1	26,1	117,5	28,7	115,7	31,6	113,9	34,9	111,4	38,4
		15	133,3	26,4	131,3	29,0	129,0	31,9	126,4	35,1	123,6	38,7
		20	148,0	26,8	145,4	29,3	142,7	32,2	139,2	35,4	135,8	39,0
500V	Pure water	-12	81,4	33,0	80,8	36,1	80,0	39,5				
		-10	87,2	33,1	86,3	36,2	85,5	39,7				
		-5	99,9	33,3	98,9	36,5	98,0	40,0	96,7	43,8	95,0	48,3
		0	113,7	33,6	112,8	36,7	111,5	40,3	110,1	44,2	108,2	48,6
		5	128,3	33,9	127,0	37,0	125,4	40,5	123,5	44,5	121,3	49,0
		7	134,6	34,0	133,0	37,1	131,2	40,6	129,0	44,7	126,7	49,1
		10	144,2	34,2	142,1	37,3	140,1	40,8	137,8	44,9	135,4	49,3
		15	161,6	34,6	159,1	37,7	156,5	41,1	153,4	45,2	150,1	49,6
		20	179,4	35,1	176,3	38,1	172,6	41,6	169,0	45,5	165,0	49,9

Pf: Cooling capacity valid for delta T according to operating limits
 Pa: Power input
 Pc: Heating capacity valid for delta T according to operating limits

Calculation fouling factor 0,00005 m² °C/W

EUROVENT conditions (EN 14511)

(1) Variation of relative humidity for following calculation:
 -20°C 95%HR / +7°C 85 %HR / +27°C 50%HR

HEATING CAPACITIES

Reversible models

ILD ILDC ILDH	External air temperature in °C WB (1)	CONDENSER WATER OUTLET TEMPERATURE IN °C										
		30		35		40		45		50		
		Pc kW	Pa kW	Pc kW	Pa kW	Pc kW	Pa kW	Pc kW	Pa kW	Pc kW	Pa kW	
540V	Pure water	-12	92,0	33,2	91,3	36,6						
		-10	96,7	33,3	95,8	36,7	95,3	41,0				
		-5	111,2	33,6	110,6	37,1	110,0	41,2	108,4	45,7		
		0	127,8	33,9	126,6	37,5	125,1	41,5	123,1	46,0	120,9	51,1
		5	143,6	34,2	142,1	37,8	140,1	41,8	137,9	46,4	135,3	51,4
		7	151,3	34,3	149,1	37,9	146,5	41,9	143,9	46,5	141,2	51,5
		10	161,1	34,4	159,1	38,0	156,4	42,1	153,6	46,6	150,7	51,7
		15	179,9	34,7	177,3	38,3	173,9	42,3	170,4	46,9	166,6	51,9
600V	Pure water	20	199,2	35,1	195,7	38,6	191,8	42,6	187,4	47,1	182,8	52,1
		-12	101,3	36,7	100,0	40,5	99,1	45,0				
		-10	110,8	37,0	109,5	40,9	108,6	45,3				
		-5	124,6	37,3	123,9	41,2	122,8	45,6	120,9	50,1		
		0	141,5	37,7	140,1	41,6	138,5	46,0	136,6	50,7	134,4	55,8
		5	159,1	38,0	157,6	42,1	155,8	46,6	153,3	51,5	150,3	56,7
		7	167,1	38,2	164,9	42,2	162,6	46,7	160,2	51,7	157,1	57,1
		10	178,1	38,4	176,2	42,4	173,6	47,0	170,9	52,0	167,9	57,5
700V	Pure water	15	198,9	38,8	196,2	42,8	193,0	47,3	189,5	52,4	185,7	58,0
		20	220,3	39,3	216,9	43,2	213,0	47,7	208,3	52,8	203,6	58,4
		-10	121,6	40,1								
		-5	138,9	40,6	136,1	44,6	135,7	48,6				
		0	156,2	41,1	154,7	45,3	152,4	49,5	151,5	55,0		
		2	164,3	41,4	162,4	45,4	160,0	49,7	158,5	55,2	156,7	61,0
		5	175,4	41,8	173,7	45,8	171,8	50,2	169,8	55,5	167,3	61,2
		7	184,0	42,2	181,4	46,1	179,2	50,5	177,0	55,8	174,3	61,4
700V	Pure water	10	196,7	42,6	193,8	46,3	191,2	50,9	188,5	56,1	185,9	61,8
		15	219,7	43,4	215,8	47,3	212,2	51,9	208,6	57,0	205,2	62,7
		20	243,1	44,2	238,0	48,1	233,8	52,5	229,3	57,7	224,8	63,4

Pf: Cooling capacity valid for delta T according to operating limits
 Pa: Power input
 Pc: Heating capacity valid for delta T according to operating limits

Calculation fouling factor 0,00005 m² °C/W
 EUROVENT conditions (EN 14511)

(1) Variation of relative humidity for following calculation:
 -20°C 95%HR / +7°C 85 %HR / +27°C 50%HR



Water chillers

HEATING CAPACITIES



Reversible models

ILD ILDC ILDH	External air temperature in °C WB (1)	CONDENSER WATER OUTLET TEMPERATURE IN °C										
		30		35		40		45		50		
		Pc kW	Pa kW	Pc kW	Pa kW	Pc kW	Pa kW	Pc kW	Pa kW	Pc kW	Pa kW	
702V	Pure water	-12	120,5	43,0	119,3	46,9	118,0	51,2	116,8	56,2		
		-10	127,5	43,3	125,9	47,2	124,5	51,6	123,3	56,6		
		-5	145,9	44,0	143,8	48,0	141,9	52,5	139,9	57,6	138,2	63,4
		0	166,9	44,7	163,9	48,8	161,3	53,4	158,4	58,6	155,7	64,6
		5	189,0	45,3	185,2	49,4	181,6	54,1	177,8	59,5	174,1	65,5
		7	198,1	45,5	194,2	49,7	189,9	54,4	187,2	60,1	182,0	65,9
		10	213,2	45,9	208,7	50,0	204,0	54,8	199,5	60,2	194,7	66,3
		15	239,7	46,6	234,0	50,7	228,1	55,4	222,4	60,8	216,3	66,9
		20	266,8	47,3	260,0	51,3	252,8	56,0	245,8	61,4	238,6	67,5
800V	Pure water	-12	132,9	48,8	131,9	53,4	130,6	58,3	128,6	63,9		
		-10	140,9	49,2	139,5	53,8	137,8	58,9	136,0	64,5		
		-5	161,1	50,1	159,5	54,9	157,6	60,1	155,2	65,9	152,8	72,4
		0	184,0	50,9	181,6	55,9	179,0	61,3	176,1	67,3	172,8	73,9
		5	208,0	51,6	204,7	56,6	201,4	62,2	197,5	68,3	193,6	75,1
		7	217,8	51,8	214,3	56,9	210,7	62,4	208,8	68,3	202,1	75,4
		10	233,9	52,3	230,0	57,3	225,8	62,8	221,2	69,1	216,1	75,9
		15	262,7	53,0	257,7	57,9	252,1	63,5	246,3	69,7	239,8	76,5
		20	292,1	53,8	285,4	58,5	278,9	64,1	271,8	70,2	264,1	77,1
900V	Pure water	-12	157,1	56,8	156,4	62,6	156,2	69,1				
		-10	165,7	57,2	164,6	63,0	163,7	69,4	163,0	76,7		
		-5	189,0	58,1	186,9	64,0	185,2	70,5	183,6	77,7	181,9	85,8
		0	215,1	59,0	212,2	64,9	209,3	71,4	206,4	78,8	203,5	86,9
		5	243,2	59,3	239,1	65,1	234,9	71,7	230,7	79,1	226,6	87,3
		7	254,9	59,6	250,4	65,5	245,6	72,0	242,1	79,4	235,8	87,6
		10	273,7	60,1	268,3	65,9	263,0	72,5	257,4	79,9	252,1	88,0
		15	307,3	61,0	300,4	66,7	293,5	73,2	286,5	80,5	279,0	88,7
		20	340,7	61,9	333,3	67,5	324,7	73,9	315,9	81,3	307,1	89,5
1000V	Pure water	-12	167,4	62,0	166,7	68,4	166,4	75,8				
		-10	176,5	62,4	175,4	68,7	174,7	76,1	174,3	84,3		
		-5	201,3	63,4	199,2	69,7	197,4	76,9	196,0	85,1	194,5	94,4
		0	229,6	64,3	226,1	70,6	222,9	77,7	220,1	85,9	217,8	95,2
		5	259,8	64,8	255,0	71,0	250,4	78,0	246,1	86,1	242,6	95,3
		7	272,4	65,1	266,9	71,3	262,0	78,3	258,6	86,7	252,5	95,6
		10	292,4	65,7	286,3	71,9	280,4	78,9	274,8	86,9	269,3	95,9
		15	328,5	66,7	320,9	72,8	313,4	79,8	305,7	87,8	298,3	96,8
		20	366,4	67,7	356,1	73,8	346,9	80,8	337,7	88,8	328,2	97,7
1100V	Pure water	-12	178,7	67,2	177,9	74,2						
		-10	188,3	67,5	187,4	74,6	186,8	82,4				
		-5	215,3	68,6	213,1	75,6	211,3	83,5	210,0	92,3		
		0	245,1	69,7	242,2	76,8	239,0	84,6	236,1	93,5	233,5	103,3
		5	277,1	70,2	272,9	77,2	268,6	85,0	264,4	93,8	259,4	103,7
		7	290,5	70,6	285,7	77,5	281,0	85,4	278,4	93,9	270,4	104,0
		10	311,1	71,2	305,8	78,2	300,4	86,0	294,6	94,8	288,7	104,5
		15	349,6	72,2	342,4	79,1	334,9	86,9	327,7	95,6	319,4	105,3
		20	388,6	73,3	379,8	80,1	371,0	87,9	361,6	96,6	352,1	106,4

R410A
LOW NOISE - LN

AQUACIAT 2

Pf: Cooling capacity valid for delta T according to operating limits
 Pa: Power input
 Pc: Heating capacity valid for delta T according to operating limits

Calculation fouling factor 0,00005 m² °C/W
 EUROVENT conditions (EN 14511)
 (1) Variation of relative humidity for following calculation:
 -20°C 95%HR / +7°C 85 %HR / +27°C 50%HR



SHELL AND TUBE EVAPORATOR

Models LD 350V to LD 1100V

LD 350V to LD 1100V water chillers without hydraulic equipment may be ordered equipped with a SHELL AND TUBE dry expansion (DX) evaporator.

This type of configuration is particularly suited to industrial or specific applications requiring a more powerful "evaporator" circuit.

Dimensions of the Aquaciat 2 shell and tube evaporator

- 1: Evaporator chilled water inlet
- 2: Evaporator chilled water outlet



LD 350V to LD 700V

LD 702V to LD 1100V

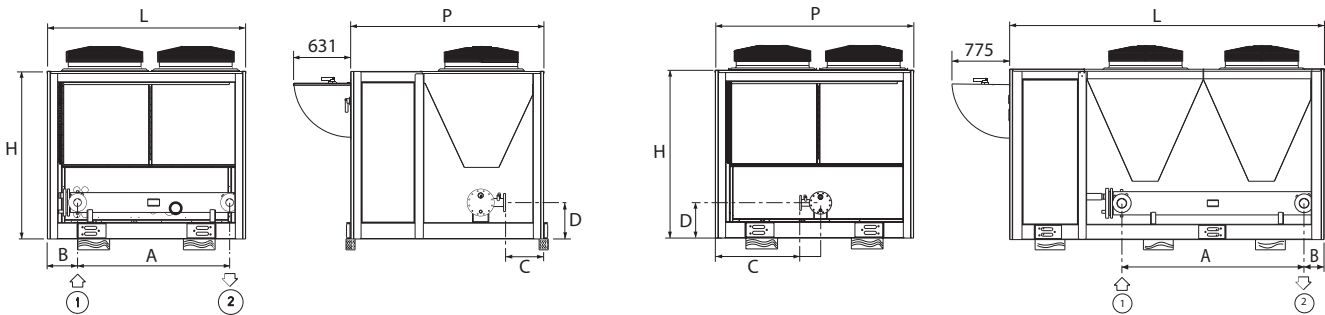

Technical specifications of the Aquaciat 2 shell and tube evaporator

LD	350 V	400 V	500 V	540 V	600 V	700 V	702 V	800 V	900 V	1000 V	1100 V
Number of cooling circuits	1	1	2	2	2	2	2	2	2	2	2
Water connections	DN 80	DN 80	DN 100	DN 100	DN 100	DN 100	DN 100	DN 100	DN125	DN125	DN125
Min. water flow rate (m ³ /h)	10	10	15	15	15	20	20	20	30	30	30
Max. water flow rate (m ³ /h) *	19	19	33	33	33	33	33	33	71	71	71
H - standard fan (mm)	2117	2117	2117	2117	2117	2117	2080	2080	2080	2080	2080
L (mm)	2190	2190	2190	2740	2740	2740	3698	3698	3698	3698	3698
P (mm)	2129	2129	2129	2129	2129	2129	2200	2200	2200	2200	2200
A (mm)	1680	1680	1640	1740	1740	2140	2140	2140	1720	1720	1720
B (mm)		333	347	608	608	360	237	237	614	614	614
C (mm)	420	420	385	20	20	20	785	785	710,5	710,5	710,5
D (mm)	403	403	427	430	430	430	426,5	426,5	468	468	468
Empty weight (kg)		1228	1433	1692	1824	2035	2347	2387	2931	3079	3119
Weight in operation (kg)		1268	1540	1781	1914	2137	2447	2487	3031	3179	3225

(*) the maximum water flow rate is given for a standard baffle spacing

Pressure drops across the shell and tube evaporator

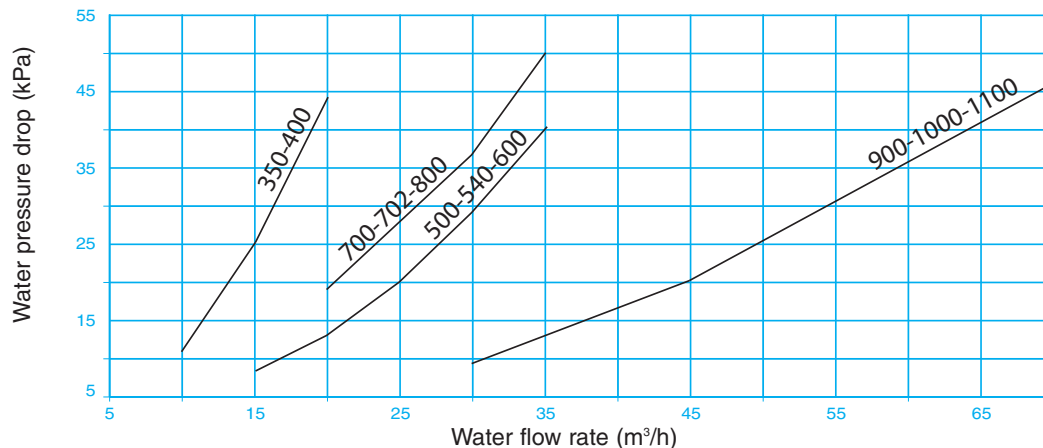

DESUPERHEATER EXCHANGER LD - ILD (STD, C OR H) SERIES

The system consists in a hot water supplying by an heat recovery system on the compressor(s) discharge gas, on an auxiliary desuperheater exchanger.

On an heat pump model, the optional desuperheater can be used whatever the running mode, COOLING or HEATING.

This optional equipment is only available on request, and factory mounted.

■ Diagram of the refrigerant circuit

The following refrigeration diagram describes an example of a CIAT heat pump unit with 1 refrigerant circuit and 2 compressors (size 180 to 400), with desuperheater.

The heat recovery is possible only if the machine is running, on COOLING mode or on HEAT PUMP mode.

For the same cooling or heating capacity, the desuperheater system allows a free heating of hot water with a reduction of the total input power of the machine.

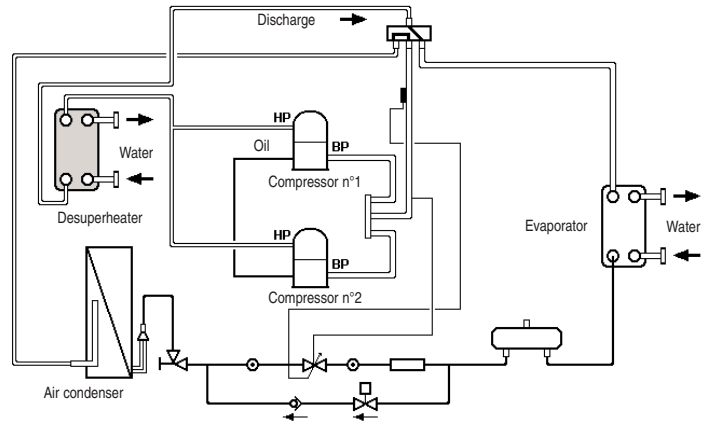

■ Principle and precautions of hydraulic connection

To make it possible the machine to start and to run under good conditions, the circuit must be as short as possible, and the water flow of the desuperheater must start slowly to normal operating condition, with a water flow equal to 10% of its standard value, and must be calculated for a hot water inlet temperature of **+50°C**.

Thus, it is recommended to have a hydraulic diagram making it possible to obtain very quickly a hot water at the inlet of the desuperheater (3 ways valve + controller + temperature sensor on the exchanger water inlet)

The controller set point must be adjusted to **+50°C** minimum.

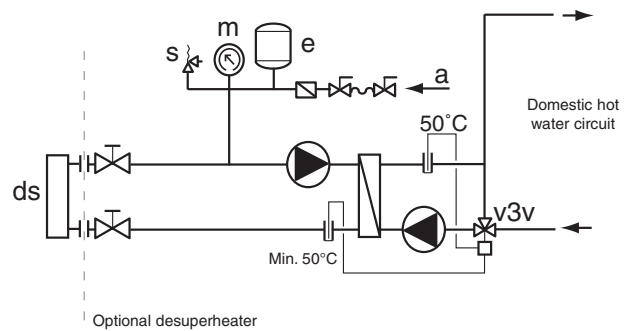

Note: a detailed attention must be carried with the selection of the expansion tank, because the recovery water circuit can reach the temperature of 120°C in the event of stopping of the circulator or non hot water consumption.

■ Recovery example on desuperheater

	Recovery Pr (kW)	Water flow qv (m³/h)	Pressure drop dP (mCE)	Number of Desuperheater	Cooling capacity Pf (kW)	Input power Pa (kW)
80V	5.9	1	1.3	1	20.2	6.9
90V	6.6	1.1	1.4	1	22.9	8.0
100V	7.9	1.4	1.2	1	27.4	9.1
120V	8.8	1.5	1.4	1	30.5	10.6
150V	11.7	2	1.4	1	40.5	13.0
180V	13.7	2.3	0.8	1	47.1	15.2
200V	15.5	2.7	1	1	53.5	18.3
240V	16	3.1	0.7	1	61.9	20.7
300V	21.9	3.8	1	1	75.6	27.6
350V	23.2	4	1.1	1	92.8	31.4
400V	26.3	4.5	1.4	1	105.2	35.2
500V	32	5.5	0.6	2	128.1	44.4
540V	35	6	0.7	2	139.9	46.1
600V	38.8	6.7	0.8	2	155.3	52.5
700V	40.8	7	0.9	2	163.1	59.5
702V	40	6.9	1.4	2	181.9	61.2
800V	44.1	7.6	1	2	200.6	69.8
900V	52.4	9	1	2	238.1	82.9
1000V	56.2	9.7	1.2	2	255.7	91.4
1100V	60.5	10.4	1	2	274.9	101.6

Note: heat recovery performances based on heat pumps, ILD series High Performances version:

- ➔ machine running on full COOLING mode, chilled water rise +12/+7°C and outdoor air temperature +35°C
- ➔ hot water temperature rise on recovery +55/+60°C



DESUPERHEATER PARTIAL HEAT RECOVERY

LD / ILD	Desuperheater water inlet and outlet temperature °C	Evaporator water outlet temperature °C	INLET AIR TEMPERATURE AT THE CONDENSER °C																				
			25				30				35				40				46				
			Pf kW	Pa kW	Pde kW	Qde m³/h	Pf kW	Pa kW	Pde kW	Qde m³/h	Pf kW	Pa kW	Pde kW	Qde m³/h	Pf kW	Pa kW	Pde kW	Qde m³/h	Pf kW	Pa kW	Pde kW	Qde m³/h	
702V	50°C / 55°C	5	190	51,5	22,8	3,9	180	55,7	32,5	5,6	170	60,4	44,2	7,6	160	65,7	65,4	11,2	146	72,9	98,1	16,9	
		7	203	52,2	24,4	4,2	193	56,4	34,7	6,0	182	61,2	47,3	8,1	171	66,5	70,0	12,0	157	73,6	105	18,1	
		12	238	54,1	28,6	4,9	226	58,3	40,7	7,0	213	63,1	55,5	9,5	200	68,6	82,1	14,1	184	75,7	123	21,3	
		15	261	55,4	31,3	5,4	248	59,7	44,6	7,7	233	64,6	60,7	10,4	220	69,9	90,1	15,5	203	77,1	135	23,3	
	55°C / 60°C	5	190	51,5	15,2	2,6	180	55,7	25,2	4,3	170	60,4	37,4	6,4	160	65,7	49,4	8,5	146	72,9	74,7	12,8	
		7	203	52,2	16,2	2,8	193	56,4	27,0	4,6	182	61,2	40,0	6,9	171	66,5	52,9	9,1	157	73,6	79,9	13,7	
		12	238	54,1	19,0	3,3	226	58,3	31,6	5,4	213	63,1	47,0	8,1	200	68,6	62,1	10,7	184	75,7	94,1	16,2	
		15	261	55,4	20,9	3,6	248	59,7	34,7	6,0	233	64,6	51,4	8,8	220	69,9	68,1	11,7	203	77,1	103	17,8	
	800V	50°C / 55°C	5	209	58,5	25,1	4,3	199	63,4	35,8	6,2	188	68,9	48,8	8,4	176	74,9	72,1	12,4	161	82,8	108	18,6
			7	224	59,3	26,8	4,6	212	64,3	38,2	6,6	201	69,8	52,2	9,0	188	75,8	77,0	13,3	172	83,7	115	19,9
			12	262	61,6	31,4	5,4	249	66,6	44,8	7,7	235	72,0	61,0	10,5	220	78,1	90,2	15,5	202	85,9	135	23,3
			15	287	63,2	34,4	5,9	272	68,1	49,0	8,4	257	73,6	66,7	11,5	241	79,6	98,8	17,0	222	87,5	148	25,5
55°C / 60°C		5	209	58,5	16,7	2,9	199	63,4	27,8	4,8	188	68,9	41,3	7,1	176	74,9	54,5	9,4	161	82,8	82,2	14,1	
		7	224	59,3	17,9	3,1	212	64,3	29,7	5,1	201	69,8	44,1	7,6	188	75,8	58,3	10,0	172	83,7	87,8	15,1	
		12	262	61,6	20,9	3,6	249	66,6	34,8	6,0	235	72,0	51,6	8,9	220	78,1	68,2	11,7	202	85,9	103	17,7	
		15	287	63,2	22,9	3,9	272	68,1	38,1	6,6	257	73,6	56,5	9,7	241	79,6	74,7	12,8	222	87,5	113	19,4	
900V		50°C / 55°C	5	250	69,0	29,9	5,1	237	75,1	42,6	7,3	223	81,6	58,1	10,0	209	88,9	85,8	14,8	192	98,4	128	22,1
			7	267	70,3	32,0	5,5	253	76,3	45,5	7,8	238	82,9	61,9	10,6	223	90,2	91,5	15,7	205	99,7	137	23,6
			12	311	73,6	37,4	6,4	295	79,6	53,1	9,1	278	86,3	72,2	12,4	260	93,7	106	18,3	239	103	160	27,6
			15	340	75,8	40,8	7,0	322	81,9	57,9	10,0	303	88,6	78,9	13,6	284	95,9	116	20,1	262	105	175	30,2
	55°C / 60°C	5	250	69,0	20,0	3,4	237	75,1	33,2	5,7	223	81,6	49,2	8,5	209	88,9	64,9	11,2	192	98,4	97,9	16,8	
		7	267	70,3	21,3	3,7	253	76,3	35,4	6,1	238	82,9	52,4	9,0	223	90,2	69,2	11,9	205	99,7	104	18,0	
		12	311	73,6	24,9	4,3	295	79,6	41,3	7,1	278	86,3	61,1	10,5	260	93,7	80,6	13,9	239	103	122	21,0	
		15	340	75,8	27,2	4,7	322	81,9	45,1	7,8	303	88,6	66,7	11,5	284	95,9	88,2	15,2	262	105	133	23,0	
	1000V	50°C / 55°C	5	269	76,3	32,3	5,5	255	82,8	45,9	7,9	240	89,9	62,3	10,7	224	97,9	92,0	15,8	206	108	138	23,8
			7	287	77,8	34,5	5,9	272	84,3	48,9	8,4	256	91,4	66,5	11,4	240	99,5	98,2	16,9	220	110	147	25,3
			12	335	81,8	40,2	6,9	317	88,4	57,1	9,8	298	95,7	77,5	13,3	280	103	114	19,7	257	114	172	29,6
			15	366	84,4	43,9	7,6	346	91,1	62,3	10,7	325	98,5	84,6	14,6	305	106	125	21,5	281	117	188	32,4
55°C / 60°C		5	269	76,3	21,5	3,7	255	82,8	35,7	6,1	240	89,9	52,7	9,1	224	97,9	69,6	12,0	206	108	105	18,1	
		7	287	77,8	23,0	4,0	272	84,3	38,0	6,5	256	91,4	56,2	9,7	240	99,5	74,3	12,8	220	110	112	19,3	
		12	335	81,8	26,8	4,6	317	88,4	44,4	7,6	298	95,7	65,6	11,3	280	103	86,7	14,9	257	114	131	22,6	
		15	366	84,4	29,3	5,0	346	91,1	48,4	8,3	325	98,5	71,6	12,3	305	106	94,6	16,3	281	117	143	24,7	
1100V		50°C / 55°C	5	286	84,3	34,3	5,9	274	91,9	49,3	8,5	258	99,8	67,1	11,5	241	108	99,0	17,0	221	119	148	25,5
			7	309	86,2	37,0	6,4	292	93,6	52,6	9,0	275	101	71,5	12,3	257	110	105	18,1	236	121	158	27,2
			12	359	90,8	43,1	7,4	340	98,2	61,2	10,5	320	106	83,2	14,3	300	115	122	21,1	275	125	184	31,7
			15	392	93,8	47,0	8,1	371	101	66,7	11,5	349	109	90,7	15,6	327	118	134	23,1	301	128	201	34,7
	55°C / 60°C	5	286	84,3	22,8	3,9	274	91,9	38,3	6,6	258	99,8	56,7	9,8	241	108	74,8	12,9	221	119	112	19,4	
		7	309	86,2	24,7	4,2	292	93,6	40,9	7,0	275	101	60,5	10,4	257	110	79,5	13,7	236	121	120	20,7	
		12	359	90,8	28,7	4,9	340	98,2	47,6	8,2	320	106	70,4	12,1	300	115	92,9	16,0	275	125	140	24,2	
		15	392	93,8	31,3	5,4	371	101	51,9	8,9	349	109	76,7	13,2	327	118	101	17,4	301	128	153	26,4	
	18	426	97,1	34,1	5,9	402	104	56,3	9,7	379	112	83,4	14,3	355	121	110	18,9	327	132	166	28,7		

Pf: Cooling capacity valid for delta T according to operating limits
Pa: Compressors power input + Fan motors

Pde: Desuperheater heating capacity recovered
Qde: Desuperheater water flow

EUROVENT conditions (EN 14511)



TOTAL RECOVERY

LD-C-H 350V-600V and LD-C-H 702V-1100V series

The LD-C-H (350V to 600V) and LD-C-H (702V to 1100V) COOLING-only chilled water units can be ordered with one or more water-cooled condensers for total waste heat recovery.

This provides an economic means of producing hot water (+30°C and +50°C) while the machine is operating in COOLING mode.

This technical configuration is particularly suited to industrial or special applications requiring high amounts of heat during the production of chilled water.

Depending on the season and the signal sent via remote control to the unit, chilled water is produced either economically by means of air-cooled condensation, or by means of water-cooled condensation with the highest possible hot water production temperature.

■ Refrigeration circuit diagram

The refrigeration diagram opposite illustrates a 350 to 500 size cooling-only unit equipped with a water-cooled heat-recovery condenser on the refrigeration circuit.

For heat recovery to be possible, the unit must be turned on following a call for chilled water production.

With equal cooling capacity, the recovery condenser can be used to produce hot water for free.

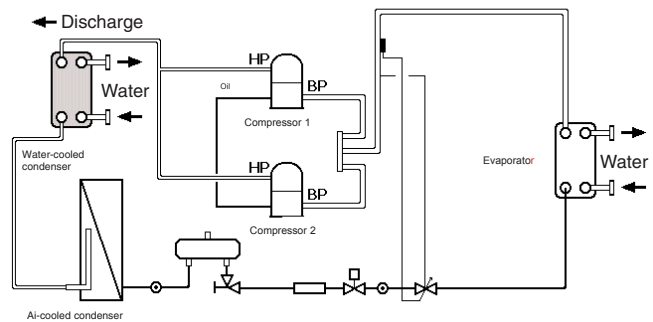

■ Principle of operation and precautions for the hydraulic connections

A dry contact (to be wired on the electronic board) must send a signal to the unit to tell it which operating mode is being called for:

- operation using the air-cooled condenser
- operation in recovery mode on the hot water circuit

In total recovery mode on the hot water circuit, the air-cooled condenser merely rejects the waste heat from the water-cooled condenser to the outdoor air.

On the 540V and higher models, two separate hydraulic circuits must be connected to the hot water supply (one per recovery condenser).

A water filtration system must be installed on the inlet to each heat exchanger. It is also recommended to use flexible connectors (options) for the hydraulic connections.

In order to ensure that the unit can start and operate under the proper conditions, the recovery condenser water loop must be as short as possible.

The system must warm up gradually so as to always ensure a water outlet temperature of at least +30°C.

We therefore recommend a hydraulic circuit configuration that makes it possible to achieve hot water at this temperature in the heat-recovery condenser (three-way valve + thermostat + sensor on heat-recovery condenser water outlet).

The thermostat setpoint must be at least +30°C.

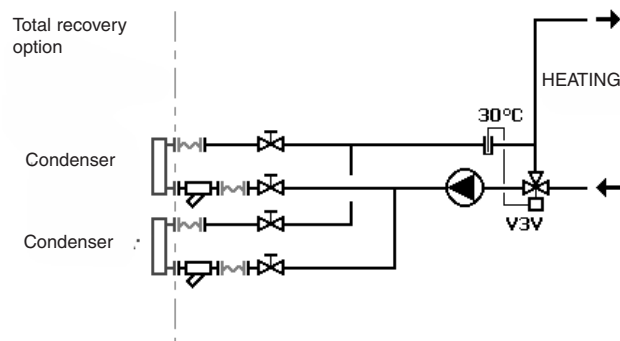

Position of total recovery heat exchangers

- 5: Condenser hot water inlet
- 6: Condenser hot water outlet

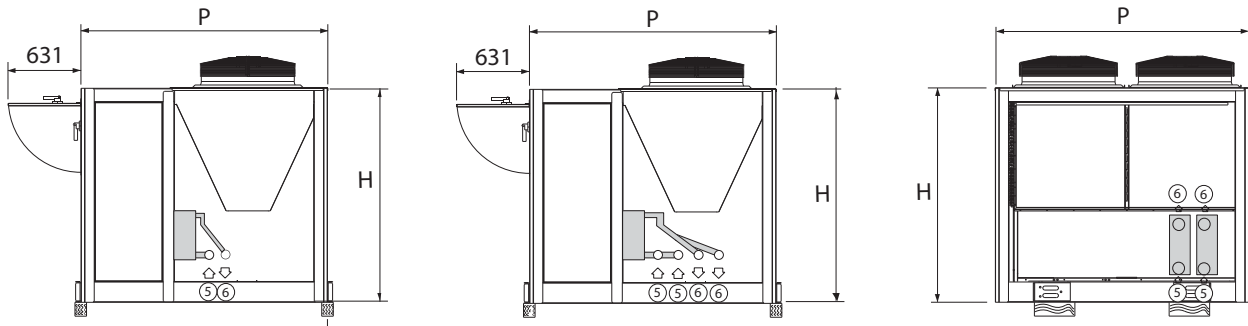

Note: refer to the dimension drawings of the units to determine the exact positions of the hydraulic connections.

Total recovery technical specifications

LD - LDC - LDH		350V	400V	500V	540V	600V	702V	800V	900V	1000V	1100V
Condenser recovery (Pc in kW) *		114,5	129,9	164,1	175,9	197,5	229,5	260,7	307,2	331,0	370,2
Number of recovery circuits		1	1	2	2	2	2	2	2	2	2
Water connections		G 2 ¹ / ₂ " M		G 2 ¹ / ₂ " M			G 2 ¹ / ₂ " M		DN 80		
MAX. water flow rate (m ³ /h)		33,2	33,2	49,5	49,5	49,5	66	66	94,8	94,8	94,8
H - standard fan (mm)		2117	2117	2117	2117	2117	2080	2080	2080	2080	2080
L (mm)		2190	2190	2190	2740	2740	3698	3698	3698	3698	3698
P (mm)		2129	2129	2129	2129	2129	2200	2200	2200	2200	2200
LD	Empty weight (kg)	1187	1286	1384	1669	1805	2460	2495	2601	2641	2696
	Weight in operation (kg)	1207	1306	1404	1692	1830	2505	2540	2646	2686	2741
LDC	Empty weight (kg)	1285	1383	1455	1863	1984	2685	2720	2841	2881	3011
	Weight in operation (kg)	1350	1413	1476	1898	2019	2745	2780	2901	2941	3071
LDH	Empty weight (kg)	1348	1447	1519	1927	2047	2835	2870	2991	3031	3131
	Weight in operation (kg)	1618	1717	1789	2207	2327	3395	3430	3551	3591	3691

(*) Note: recovery performance based on:
 - unit under full load (chilled water: +12°C/+7°C)
 - recovery hot water temperature range of +40°C/+45°C

Pressure drops of the total recovery water-cooled condenser

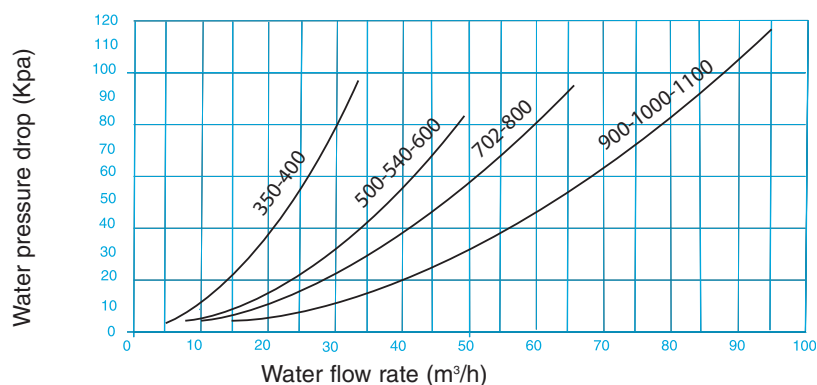



Water chillers

RECUPERATION TOTALE

AQUACIAT 2

R410A

TOTAL RECOVERY

LD LDC LDH	Evaporator water outlet temperature (°C)	RECOVERY CONDENSER WATER OUTLET TEMPERATURE (°C)															
		30			35			40			45			50			
		Pf kW	Pa kW	Pc kW	Pf kW	Pa kW	Pc kW	Pf kW	Pa kW	Pc kW	Pf kW	Pa kW	Pc kW	Pf kW	Pa kW	Pc kW	
350V	Glycol/water mix	-12	43,8	18,1	62,0	41,5	20,0	61,5	38,4	22,0	60,4						
		-10	52,0	18,5	70,6	49,8	20,4	70,2	46,5	22,4	68,9	43,8	24,8	68,6	40,1	27,3	67,4
		-8	56,6	18,7	75,4	53,8	20,6	74,4	50,9	22,7	73,6	47,7	25,1	72,8	44,0	27,6	71,6
		-4	66,3	19,1	85,3	63,6	21,1	84,7	59,8	23,2	83,0	55,7	25,6	81,3	51,9	28,3	80,2
		0	78,4	19,4	97,8	74,8	21,4	96,2	70,3	23,6	93,9	65,8	26,1	91,9	61,4	28,9	90,3
	Pure water	5	95,5	19,9	115,4	91,4	21,9	113,3	86,9	24,2	111,0	81,7	26,7	108,4	76,4	29,6	106,0
		7	104,3	20,1	124,5	98,6	22,1	120,6	93,8	24,3	118,1	87,6	26,9	114,5	81,6	29,7	111,3
		12	123,2	20,7	143,9	117,3	22,6	139,9	111,2	24,8	136,0	103,7	27,4	131,1	97,2	30,2	127,4
		15	135,9	21,1	157,1	129,5	23,0	152,4	122,0	25,2	147,1	114,5	27,7	142,2	107,0	30,5	137,5
		18	149,7	21,6	171,3	142,5	23,4	165,9	134,6	25,5	160,1	126,7	28,1	154,7	118,1	30,9	148,9
400V	Glycol/water mix	-12	55,3	21,2	76,5	52,2	23,4	75,6	49,2	25,7	74,9	45,9	28,3	74,2			
		-10	60,6	21,5	82,1	56,6	23,6	80,3	53,8	26,1	79,9	50,1	28,7	78,8	46,0	31,6	77,6
		-8	65,3	21,7	87,0	61,5	23,9	85,4	58,1	26,4	84,5	54,2	29,1	83,3	50,6	32,1	82,7
		-4	75,6	22,0	97,7	72,0	24,4	96,4	67,9	27,0	94,9	63,7	29,8	93,5	59,0	32,8	91,8
		0	88,9	22,5	111,4	84,4	24,8	109,2	79,6	27,4	107,0	75,2	30,3	105,5	69,9	33,5	103,4
	Pure water	5	109,7	23,0	132,7	104,7	25,3	130,0	99,0	28,0	127,0	92,7	30,9	123,7	85,9	34,1	120,0
		7	117,4	23,2	140,6	111,8	25,5	137,3	105,7	28,2	133,9	98,8	31,1	129,9	92,4	34,3	126,7
		12	138,9	23,8	162,6	132,3	26,0	158,3	124,9	28,7	153,5	117,0	31,6	148,6	109,2	34,8	143,9
		15	153,2	24,2	177,4	146,7	26,4	173,1	137,7	29,0	166,7	129,4	31,9	161,2	120,6	35,1	155,6
		18	168,4	24,7	193,1	160,8	26,8	187,6	152,3	29,3	181,6	142,2	32,2	174,3	132,8	35,3	168,1
500V	Glycol/water mix	-12	70,0	26,2	96,2	66,3	28,9	95,2	62,9	31,7	94,6	58,6	35,2	93,8			
		-10	76,4	26,5	102,9	71,9	29,2	101,2	68,1	32,1	100,2	63,1	35,5	98,6	58,9	39,3	98,2
		-8	82,6	26,8	109,4	77,7	29,5	107,3	73,1	32,5	105,6	68,9	36,0	104,9	63,8	39,7	103,5
		-4	95,9	27,4	123,3	90,6	30,2	120,7	85,3	33,2	118,5	80,2	36,6	116,8	74,7	40,5	115,3
		0	113,7	28,0	141,7	108,0	30,8	138,8	101,5	33,9	135,5	94,4	37,5	131,9	88,3	41,3	129,5
	Pure water	5	140,0	28,8	168,8	132,9	31,6	164,5	125,2	34,7	160,0	117,2	38,3	155,5	108,7	42,1	150,8
		7	150,0	29,0	179,0	142,4	31,8	174,2	134,3	35,0	169,3	125,5	38,5	164,1	117,0	42,4	159,4
		12	176,0	29,7	205,8	168,1	32,4	200,5	159,0	35,7	194,7	148,7	39,2	187,9	138,6	43,1	181,7
		15	195,6	30,1	225,7	186,3	32,9	219,1	175,3	36,1	211,3	164,5	39,6	204,1	153,3	43,5	196,8
		18	214,9	30,6	245,4	205,0	33,4	238,3	193,4	36,5	229,9	181,6	40,0	221,6	171,2	44,0	215,2
540V	Glycol/water mix	-12	70,5	28,0	98,5	67,7	30,9	98,6	62,8	34,1	96,9						
		-10	82,2	28,4	110,7	77,8	31,6	109,3	72,4	34,9	107,3	67,3	38,5	105,8	60,8	42,6	103,4
		-8	88,8	28,6	117,4	84,5	31,9	116,3	79,0	35,3	114,3	73,3	39,1	112,4	65,8	43,1	108,9
		-4	103,0	29,1	132,0	99,1	32,3	131,5	92,9	36,0	128,8	86,4	39,9	126,3	79,4	44,2	123,6
		0	119,4	29,4	148,8	116,0	32,7	148,8	109,3	36,5	145,8	101,9	40,6	142,5	94,1	45,0	139,1
	Pure water	5	147,1	29,9	177,0	141,9	33,2	175,1	133,8	37,0	170,8	125,5	41,2	166,7	116,4	45,8	162,1
		7	159,8	30,2	190,0	152,5	33,4	185,9	143,8	37,2	180,9	134,5	41,4	175,9	125,2	46,0	171,1
		12	189,1	31,0	220,0	179,3	34,0	213,2	169,6	37,6	207,2	158,7	41,8	200,5	147,8	46,4	194,1
		15	204,8	31,5	236,3	196,9	34,4	231,3	186,7	38,0	224,7	174,5	42,0	216,6	162,1	46,6	208,7
		18	225,9	32,3	258,3	216,3	35,0	251,3	204,3	38,4	242,7	191,8	42,4	234,2	178,9	46,9	225,8
600V	Glycol/water mix	-12	84,2	32,2	116,5	78,8	35,3	114,1	74,7	39,0	113,6	70,3	42,8	113,1			
		-10	92,0	32,6	124,5	86,7	36,0	122,7	81,7	39,7	121,4	76,3	43,5	119,8	69,6	47,6	117,2
		-8	99,1	32,8	131,9	93,8	36,4	130,2	89,2	40,2	129,4	83,3	44,3	127,6	75,9	48,4	124,3
		-4	115,0	33,3	148,3	109,4	37,0	146,4	104,0	41,0	145,0	97,2	45,3	142,5	89,5	49,8	139,3
		0	135,1	33,7	168,8	128,6	37,4	166,0	121,7	41,6	163,4	113,8	46,1	160,0	105,9	50,9	156,8
	Pure water	5	164,9	34,3	199,2	157,6	38,0	195,6	148,4	42,3	190,7	140,7	46,9	187,6	131,0	51,9	182,9
		7	176,4	34,6	211,0	168,6	38,2	206,8	160,3	42,5	202,8	150,4	47,1	197,5	139,9	52,1	192,1
		12	208,8	35,6	244,5	199,1	39,0	238,1	188,3	43,0	231,3	177,2	47,6	224,8	165,2	52,7	217,9
		15	229,7	36,4	266,1	217,5	39,5	257,0	207,8	43,5	251,3	195,4	48,0	243,4	181,9	52,9	234,9
		18	250,6	37,4	288,0	240,3	40,3	280,7	228,0	44,0	272,1	213,9	48,4	262,3	200,3	53,4	253,6



RECUPERATION TOTALE

LD LDC LDH	Evaporator water outlet temperature (°C)	RECOVERY CONDENSER WATER OUTLET TEMPERATURE (°C)															
		30			35			40			45			50			
		Pf kW	Pa kW	Pc kW	Pf kW	Pa kW	Pc kW	Pf kW	Pa kW	Pc kW	Pf kW	Pa kW	Pc kW	Pf kW	Pa kW	Pc kW	
702V	Glycol/water mix	-12	92,8	36,4	129,2	90,2	40,2	130,4	86,2	43,8	130,0						
		-10	104,6	37,0	141,6	99,1	40,7	139,8	93,3	44,2	137,5	85,4	49,3	134,7			
		-8	113,8	37,4	151,2	107,5	41,1	148,5	102,0	45,0	147,0	94,0	49,9	144,0	87,6	55,2	142,8
		-4	133,1	38,1	171,2	126,6	42,0	168,6	119,0	46,0	165,0	111,3	51,1	162,4	103,3	56,5	159,8
		0	155,5	38,7	194,2	149,0	42,7	191,7	141,3	47,2	188,5	131,7	52,2	183,9	122,8	57,8	180,6
	Pure water	5	193,2	39,7	232,9	184,9	43,7	228,6	174,6	48,3	222,9	163,5	53,3	216,8	148,8	58,9	207,7
		7	208,1	40,1	248,2	198,7	44,1	242,8	187,3	48,6	235,9	175,8	53,7	229,5	163,4	59,4	222,8
		12	244,4	41,2	285,7	233,6	45,1	278,7	220,5	49,6	270,1	208,2	54,7	263,0	194,1	60,3	254,4
		15	269,7	42,0	311,7	258,9	45,9	304,8	244,1	50,2	294,3	229,2	55,3	284,5	213,9	61,0	274,9
		18	299,5	43,1	342,6	285,6	46,8	332,4	269,8	51,0	320,8	252,1	56,0	308,1	235,5	61,6	297,1
800V	Glycol/water mix	-12	110,2	42,4	152,6	102,5	46,5	149,0	95,0	51,0	146,0	90,2	56,4	146,7			
		-10	119,5	42,9	162,4	113,9	47,3	161,2	107,2	52,2	159,4	100,5	57,5	158,0			
		-8	131,0	43,5	174,5	123,7	47,9	171,6	116,3	52,9	169,2	108,7	58,3	166,9	100,6	64,1	164,7
		-4	151,4	44,1	195,5	145,1	48,8	194,0	136,1	53,9	190,0	127,6	59,6	187,2	117,9	65,6	183,5
		0	174,4	44,8	219,1	168,0	49,6	217,6	157,8	54,7	212,5	149,4	60,6	210,1	138,8	66,9	205,7
	Pure water	5	215,7	45,9	261,5	209,3	50,7	260,0	197,9	56,0	253,9	185,5	61,9	247,4	172,0	68,2	240,1
		7	235,6	46,4	282,0	223,9	51,1	275,0	210,4	56,3	266,6	198,4	62,3	260,7	184,7	68,6	253,2
		12	276,8	47,5	324,3	265,0	52,1	317,1	249,9	57,3	307,1	234,7	63,2	297,9	218,6	69,6	288,2
		15	305,7	48,3	354,0	290,6	52,8	343,4	276,0	57,9	333,9	258,4	63,7	322,1	240,8	70,1	310,9
		18	334,4	49,3	383,7	320,9	53,6	374,5	303,7	58,6	362,3	284,7	64,3	349,0	266,0	70,7	336,7
900V	Glycol/water mix	-12	126,7	47,6	174,3	123,8	53,8	177,6	117,0	59,6	176,6						
		-10	140,0	48,1	188,1	134,4	54,0	188,5	127,6	60,0	187,6	119,6	66,5	186,1			
		-8	153,1	48,7	201,8	146,2	54,5	200,6	138,8	60,4	199,2	130,3	67,0	197,3			
		-4	180,0	49,8	229,8	172,4	55,4	227,8	163,4	61,3	224,7	152,3	67,9	220,2	142,4	75,1	217,5
		0	210,8	51,1	261,9	202,1	56,4	258,5	191,6	62,4	253,9	180,5	69,1	249,5	168,0	76,4	244,4
	Pure water	5	262,4	52,8	315,2	249,6	58,0	307,6	237,9	64,0	301,9	220,5	70,5	291,1	207,3	78,2	285,5
		7	279,9	53,2	333,1	265,0	58,3	323,4	254,2	64,5	318,6	236,1	71,1	307,2	222,1	78,7	300,8
		12	332,8	54,8	387,6	314,0	59,8	373,8	297,1	65,6	362,7	282,1	72,6	354,7	262,9	80,0	343,0
		15	368,4	56,0	424,4	350,8	61,0	411,8	332,1	66,8	399,0	311,9	73,5	385,4	291,0	80,9	371,9
		18	405,1	57,2	462,3	383,7	62,0	445,7	364,9	67,8	432,7	342,9	74,4	417,3	320,6	81,9	402,5
1000V	Glycol/water mix	-12	136,0	53,3	189,3	130,6	58,2	188,8	124,0	64,5	188,5	115,9	72,2	188,1			
		-10	150,0	54,0	204,0	144,4	59,6	204,0	136,4	65,6	202,0	127,4	72,6	200,1	118,7	81,0	199,7
		-8	164,1	54,8	218,9	157,6	60,2	217,8	148,6	66,2	214,7	139,7	73,2	212,9	129,0	81,4	210,3
		-4	194,3	56,1	250,4	185,5	61,5	247,0	175,4	67,5	242,9	165,0	74,5	239,5	153,1	82,5	235,5
		0	227,5	57,4	284,8	216,9	62,9	279,7	206,8	69,1	275,9	194,9	76,0	270,9	181,7	84,0	265,7
	Pure water	5	283,1	58,9	342,0	271,2	64,7	335,9	256,4	71,0	327,3	241,7	78,0	319,8	224,6	86,1	310,7
		7	307,6	59,5	367,1	292,1	65,3	357,4	275,5	71,8	347,2	252,6	78,3	331,0	241,6	86,7	328,3
		12	363,9	60,3	424,2	346,6	66,4	413,0	326,4	72,9	399,3	307,7	80,2	387,9	286,3	88,0	374,3
		15	402,1	60,7	462,8	382,5	67,0	449,5	362,3	73,7	436,0	338,5	80,9	419,4	315,8	88,8	404,6
		18	443,6	61,0	504,6	420,7	67,5	488,2	395,7	74,2	470,0	371,9	81,7	453,6	348,2	89,7	437,9
1100V	Glycol/water mix	-12	154,5	59,1	213,6	148,1	65,5	213,6	137,0	71,9	208,9	125,0	79,8	204,8			
		-10	166,0	59,5	225,5	159,6	66,0	225,6	151,7	73,0	224,7	142,0	80,8	222,8			
		-8	182,7	60,4	243,1	173,9	66,7	240,6	164,3	73,6	238,0	153,9	81,4	235,4	142,9	90,5	233,3
		-4	214,6	61,9	276,5	205,0	68,1	273,1	192,8	75,0	267,8	181,4	83,0	264,4	168,2	91,7	259,9
		0	249,9	63,2	313,1	240,1	69,6	309,7	226,4	76,6	303,0	212,8	84,5	297,3	197,9	93,3	291,2
	Pure water	5	311,0	64,8	375,8	296,9	71,3	368,3	278,7	78,4	357,1	264,7	86,5	351,2	246,0	95,3	341,3
		7	335,2	65,4	400,7	318,4	71,9	390,4	300,9	79,1	379,9	283,2	87,0	370,2	262,9	95,8	358,7
		12	397,7	66,8	464,5	377,8	73,3	451,1	356,7	80,6	437,2	335,8	88,6	424,4	312,2	97,3	409,5
		15	439,2	67,5	506,7	417,3	74,2	491,5	394,1	81,4	475,5	369,9	89,5	459,4	345,1	98,2	443,3
		18	482,8	68,1	550,9	460,4	74,9	535,3	434,0	82,3	516,3	406,7	90,4	497,1	380,0	99,3	479,3

R410A
TOTAL RECOVERY



EXCHANGER PRESSURE DROPS LD - ILD

(do not extrapolate)

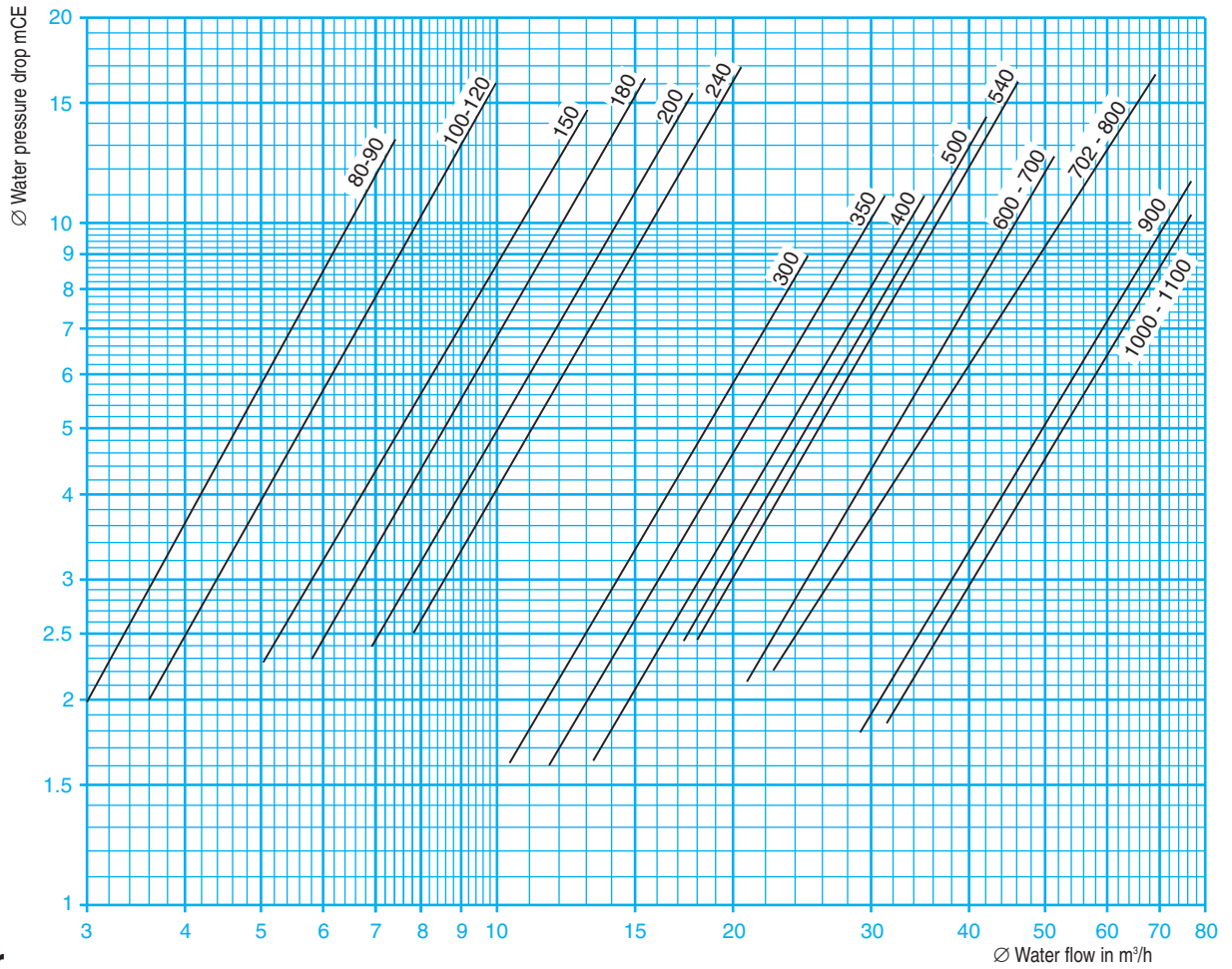

Filter

(Compulsory)

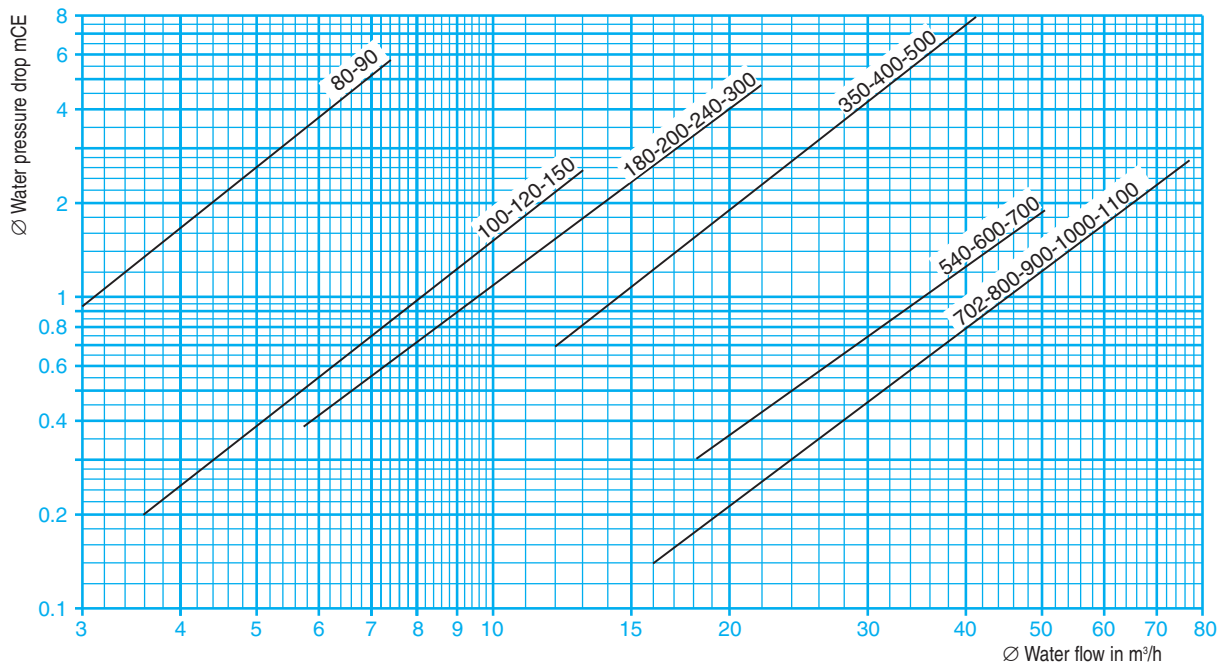



EXCHANGER PRESSURE DROPS LDC - LDH - ILDC - ILDH

(do not extrapolate)

AQUACIAT 2 / 80 to 150

Evaporator and hydraulic circuit

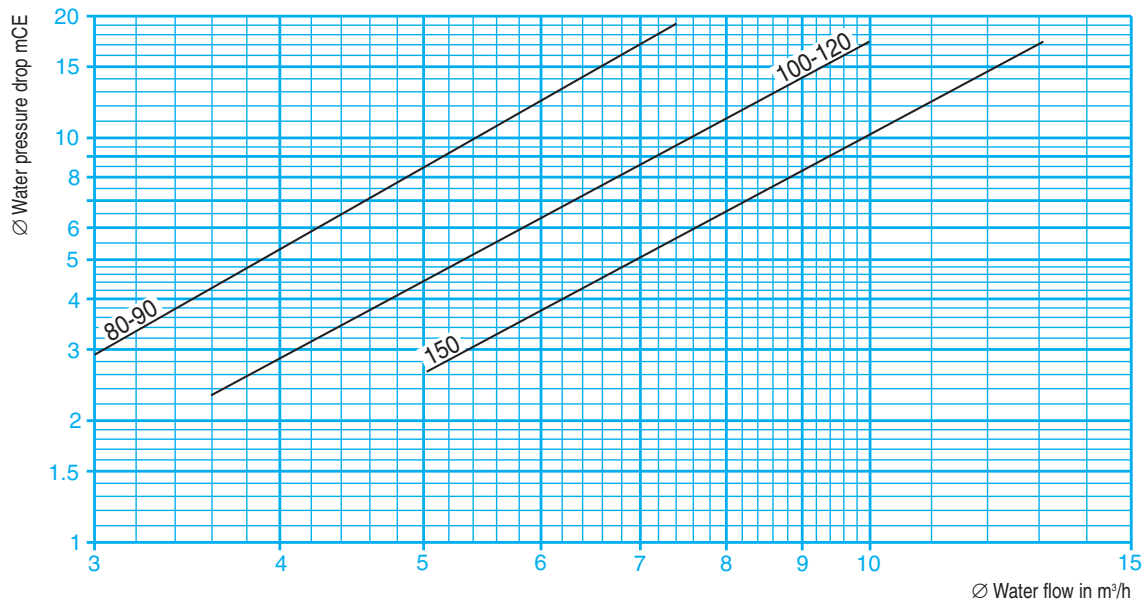

Single pumps

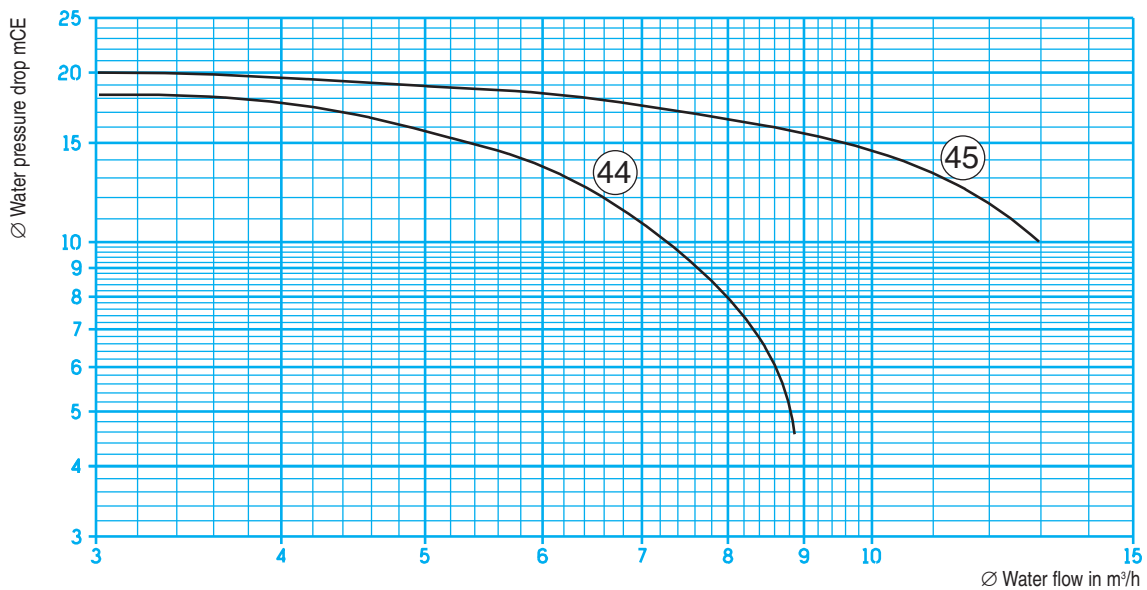



Water chillers

EXCHANGER PRESSURE DROPS LDC- LDH - ILDC - ILDH

(do not extrapolate)

AQUACIAT 2 / 180 to 300

Evaporator and hydraulic circuit

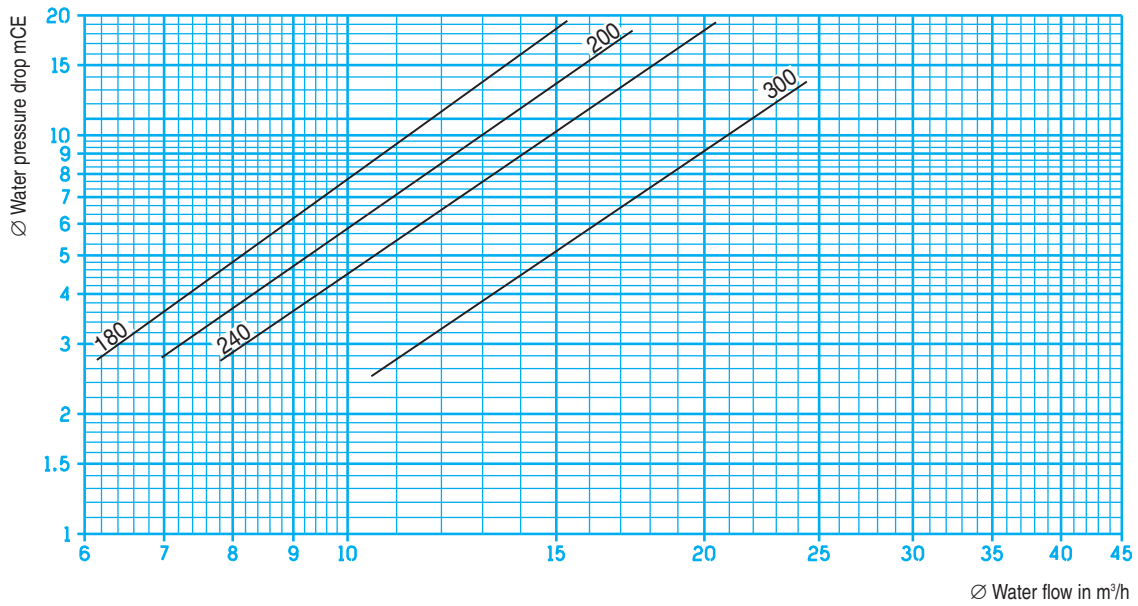

Single pumps or 2 single pumps in parallel

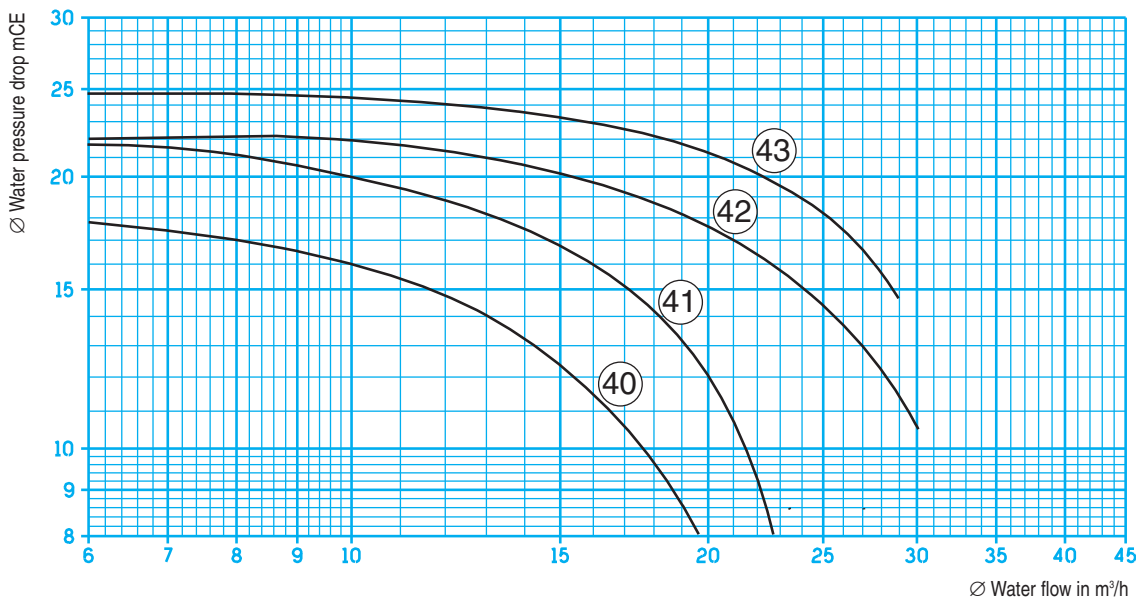



EXCHANGER PRESSURE DROPS LDC - LDH - ILDC - ILDH

(do not extrapolate)

AQUACIAT 2 / 350 to 700

Evaporator and hydraulic circuit

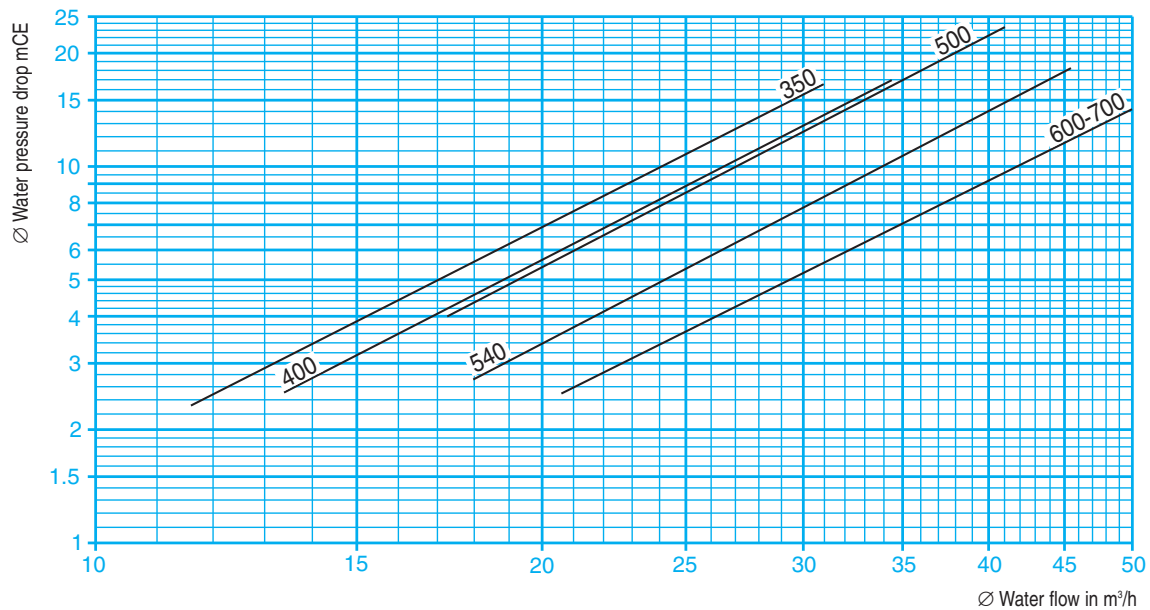

Single pumps or 2 single pumps in parallel (40-41-42-43) or twin pumps (217-218-219)

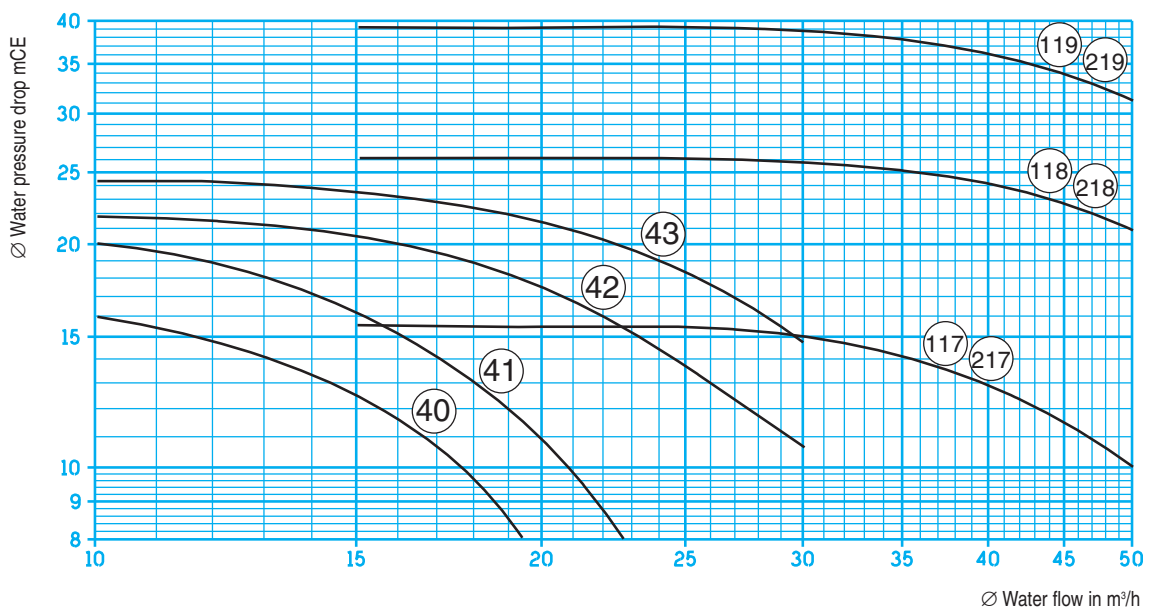



Water chillers

EXCHANGER PRESSURE DROPS LDC - LDH - ILDC - ILDH

(do not extrapolate)

AQUACIAT 2 / 753 to 1200

Evaporator and hydraulic circuit

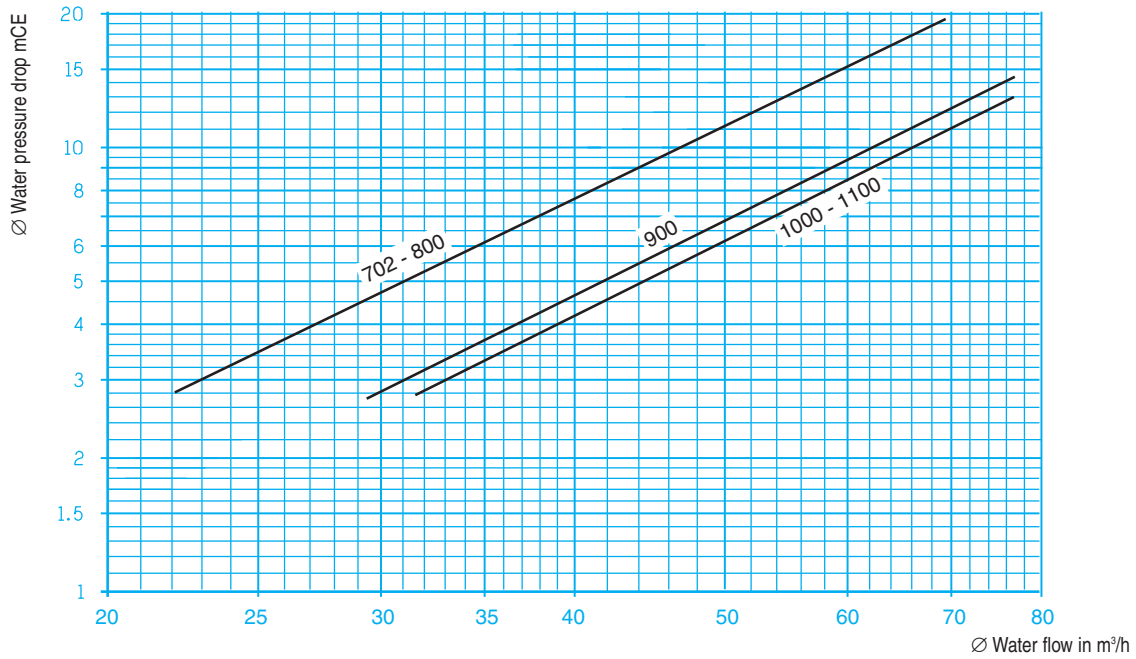

117 - 118 - 119: Single pump

217 - 218 - 219: Twine pump

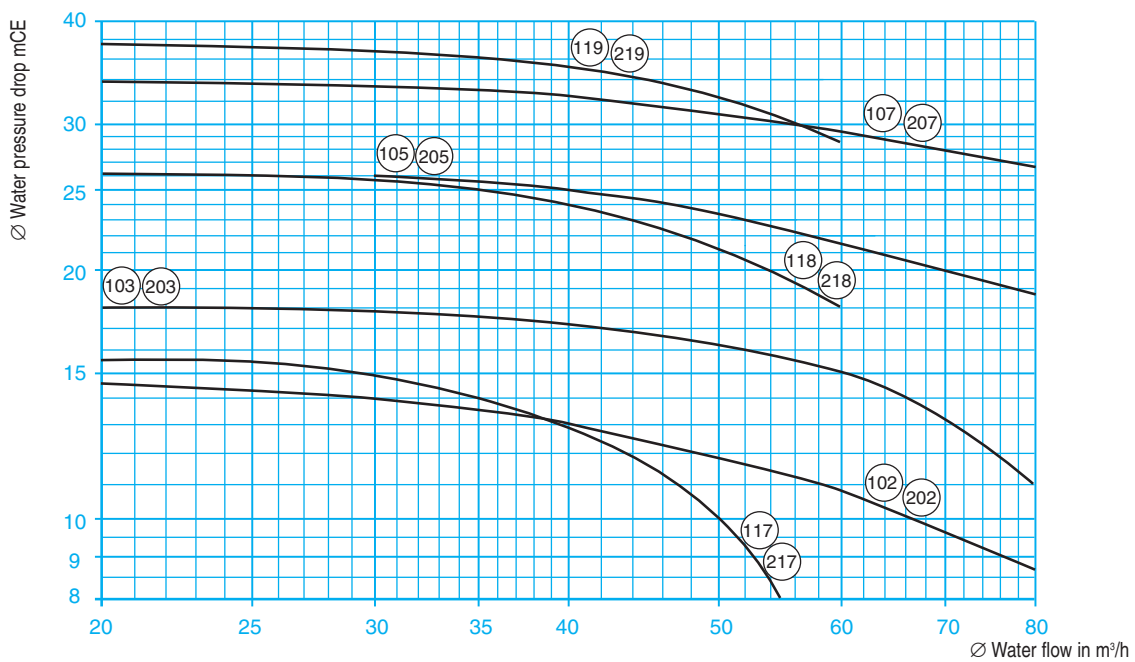



DESUPERHEATER PRESSURE DROPS

AQUACIAT 2

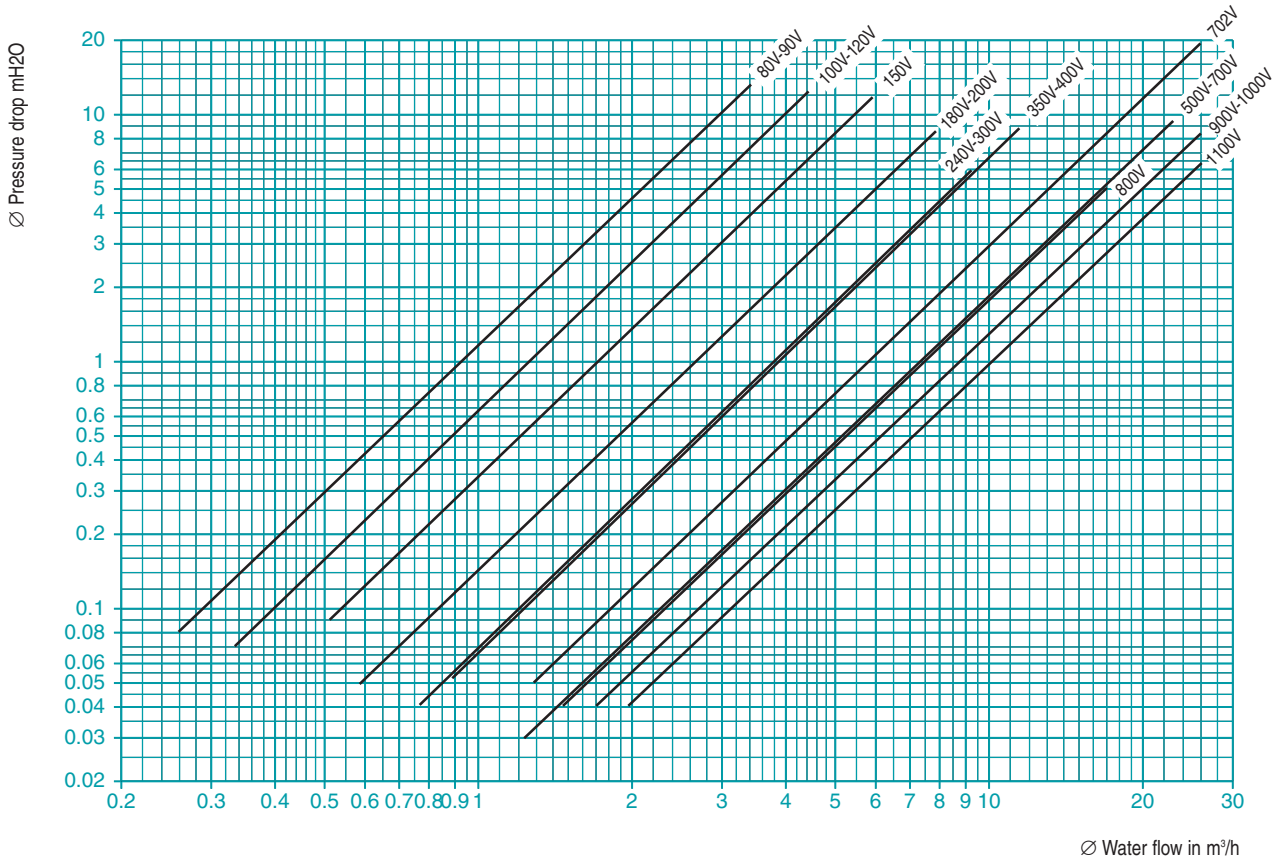

NOTE



.....
.....
.....
.....
.....
.....
.....
.....
.....
.....
.....
.....
.....
.....
.....
.....
.....
.....
.....
.....
.....

DIMENSIONS

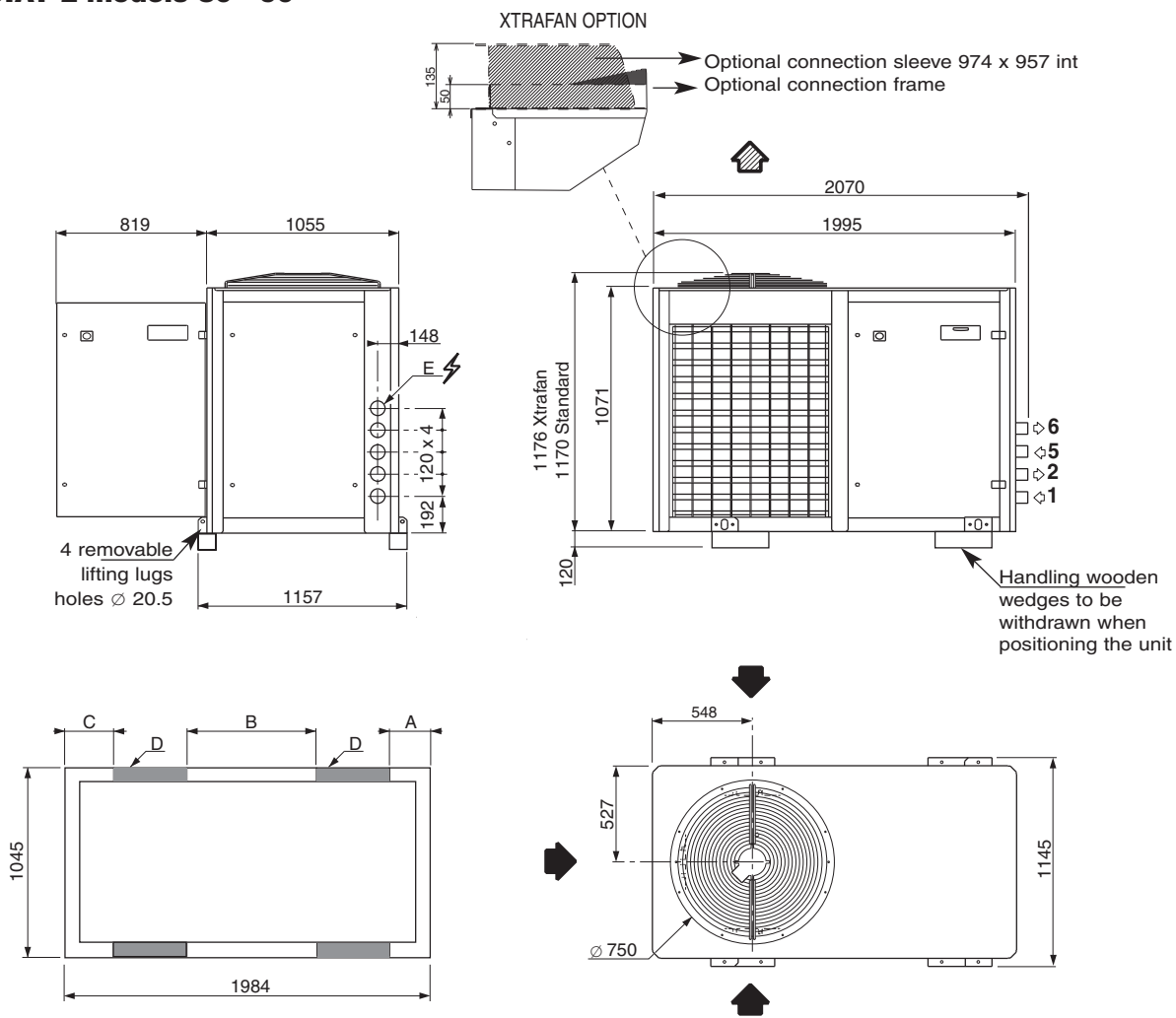
AQUACIAT 2 models 80 - 90



A clear space of 1 m on all sides of the units should be allowed for servicing and maintenance operations.

-  Outside air discharge
-  Outside air inlet

- 5: Hot water inlet G 3/4" M
- 6: Hot water outlet G 3/4" M
- 1: Chilled water inlet G 1 1/4" M
- 2: Chilled water outlet G 1 1/4" M
- E: Electrical supply \varnothing 80

Aquaciat 2	Mounts position				Antivibration mounts	Mass in kg	
	A	B	C	D		empty	in operation
LD 80	250	1284	250	P25 50 x 100	326	331	
					329	334	
LDC 80	250	1284	250	P25 50 x 100	344	349	
					347	352	
LDH 80	140	1114	490	P25 50 x 120	369	474	
					372	477	
ILD 80	250	1284	250	P25 50 x 100	328	333	
					331	336	
ILDC 80	250	1284	250	P25 50 x 100	346	351	
					349	354	
ILDH 80	140	1114	490	P25 50 x 120	371	476	
					374	479	

DIMENSIONS

AQUACIAT 2 models 100 to 150

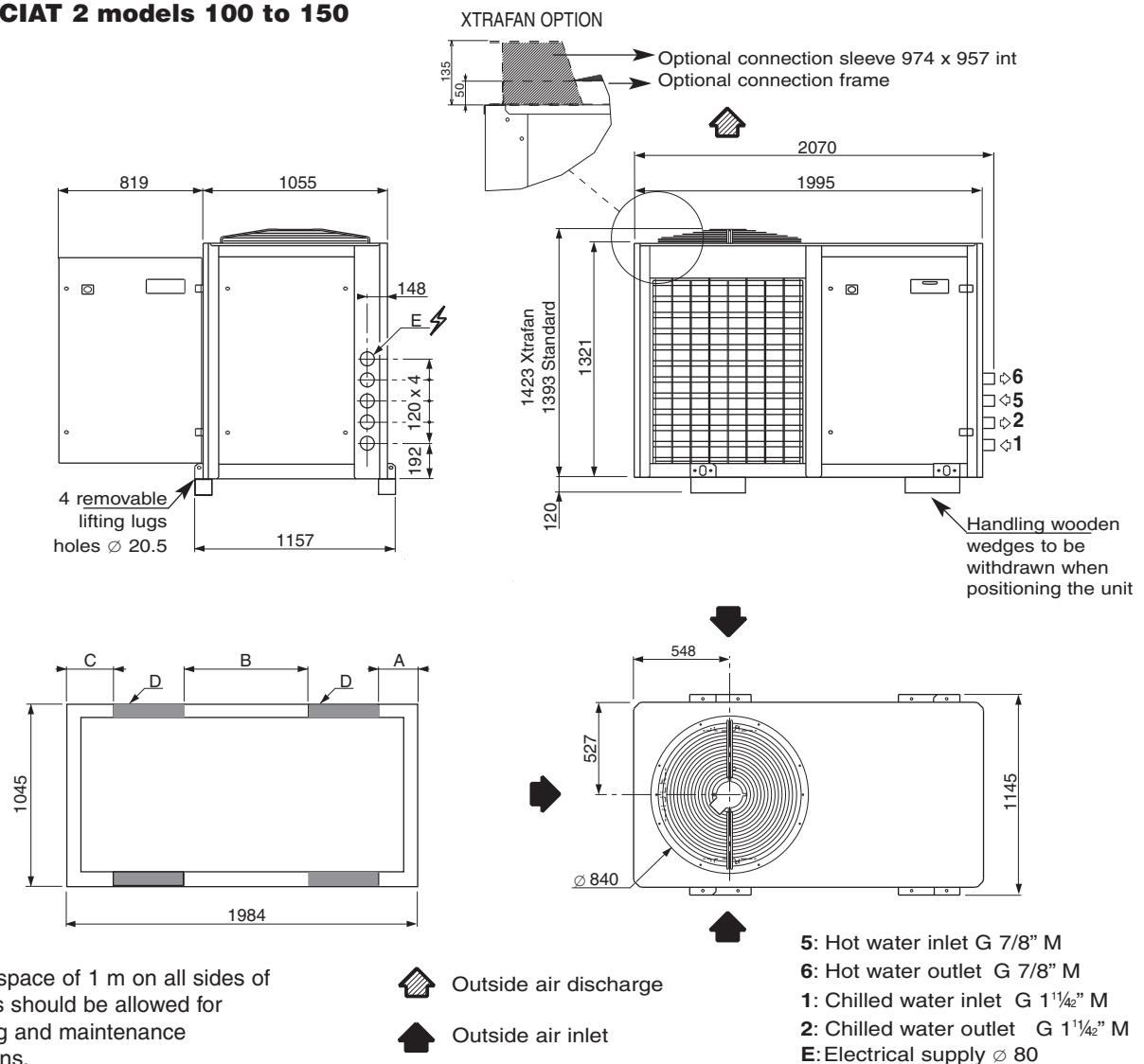

A clear space of 1 m on all sides of the units should be allowed for servicing and maintenance operations.

Aquaciat 2	Mounts position				Antivibration mounts	Mass in kg	
	A	B	C	D		empty	in operation
LD	100	250	1284	250	P25 50 x 100	365	370
	120	250	1284	250		367	372
	150	240	1264	240		449	454
LDC	100	250	1284	250	P25 50 x 100	383	388
	120	250	1284	250		385	390
	150	240	1264	240		467	472
LDH	100	125	1084	475	P25 50 x 150	407	562
	120	125	1084	475		409	564
	150	125	1084	475		492	647
ILD	100	250	1284	250	P25 50 x 100	366	371
	120	250	1284	250		368	373
	150	240	1264	240		452	457
ILDC	100	250	1284	250	P25 50 x 100	384	389
	120	250	1284	250		386	391
	150	240	1264	240		470	475
ILDH	100	125	1084	475	P25 50 x 150	409	564
	120	125	1084	475		411	566
	150	125	1084	475		495	650



DIMENSIONS

AQUACIAT 2 LD - LDC - ILD - ILDC models 180 to 300

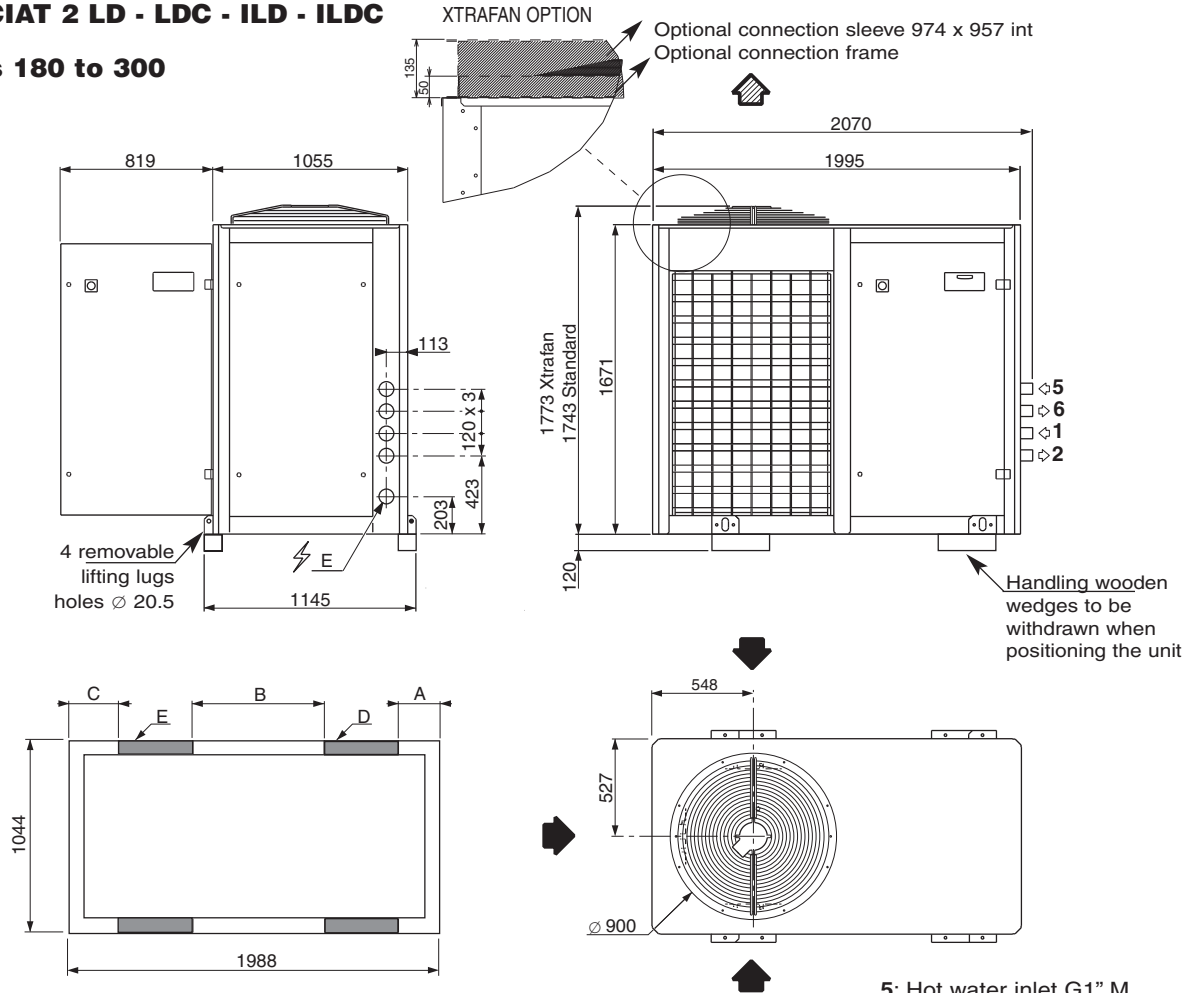

A clear space of 1 m on all sides of the units should be allowed for servicing and maintenance operations.

Outside air discharge

Outside air inlet

- 5: Hot water inlet G1" M
- 6: Hot water outlet G1" M
- 1: Chilled water inlet G 2" M
- 2: Chilled water outlet G 2" M
- E: Electrical supply \varnothing 80

Aquaciat 2	Mounts position			Antivibration mounts		Mass in kg	
	A	B	C	D	E	empty	in operation
LD	180	100	328	P25 50 x 150	P25 50 x 150	564	570
	200					570	574
	240					576	580
	300					706	712
LDC	180	100	400	P25 50 x 200	P25 50 x 120	611	615
	200					614	618
	240					620	624
	300					751	755
ILD	180	150	300	P25 50 x 200	P25 50 x 120	611	615
	200					614	618
	240					620	624
	300					756	760
ILDC	180	100	350	P25 50 x 200	P25 50 x 150	648	652
	200					651	655
	240					656	660
	300					789	793

DIMENSIONS

AQUACIAT 2 LDH - ILDH

models 180 to 300

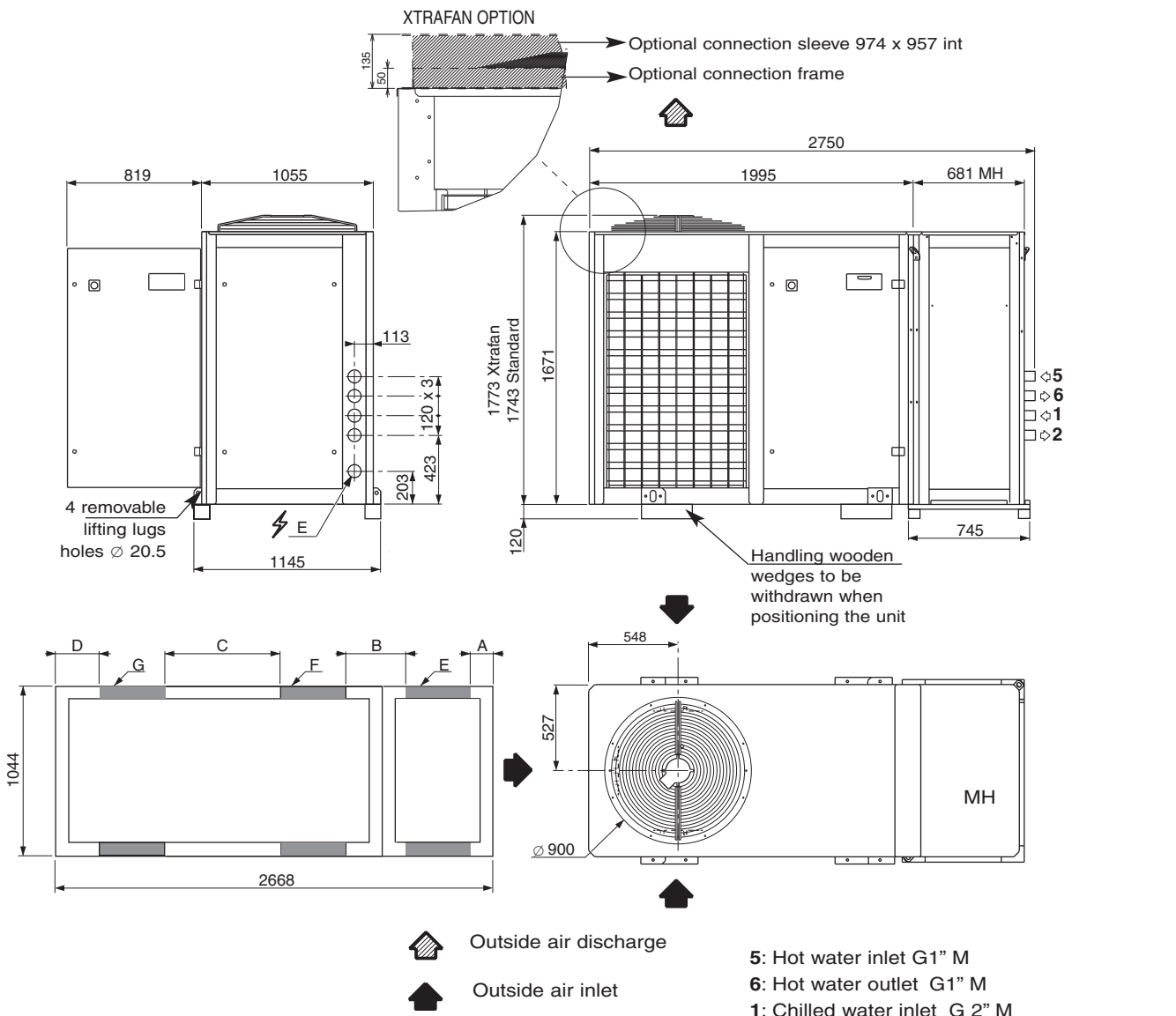

A clear space of 1 m on all sides of the units should be allowed for servicing and maintenance operations.

- 5: Hot water inlet G1" M
- 6: Hot water outlet G1" M
- 1: Chilled water inlet G 2" M
- 2: Chilled water outlet G 2" M
- E: Electrical supply Ø 80
- MH = Hydraulic module delivered separately

Aquadat 2	Mounts position				Antivibration mounts			Mass in kg	
	A	B	C	D	E	F	G	empty	in operation
LDH 180								808	1012
ILDH 180								845	1049
LDH 200								811	1015
ILDH 200	196	600	1156	196	P25 50 x 200	P25 50 x 200	P25 50 x 120	848	1052
LDH 240								817	1021
ILDH 240								853	1057
LDH 300								948	1152
ILDH 300	196	600	1076	196	P25 50 x 200	P25 50 x 200	P25 50 x 200	986	1190

DIMENSIONS

AQUACIAT 2 models 350 to 500

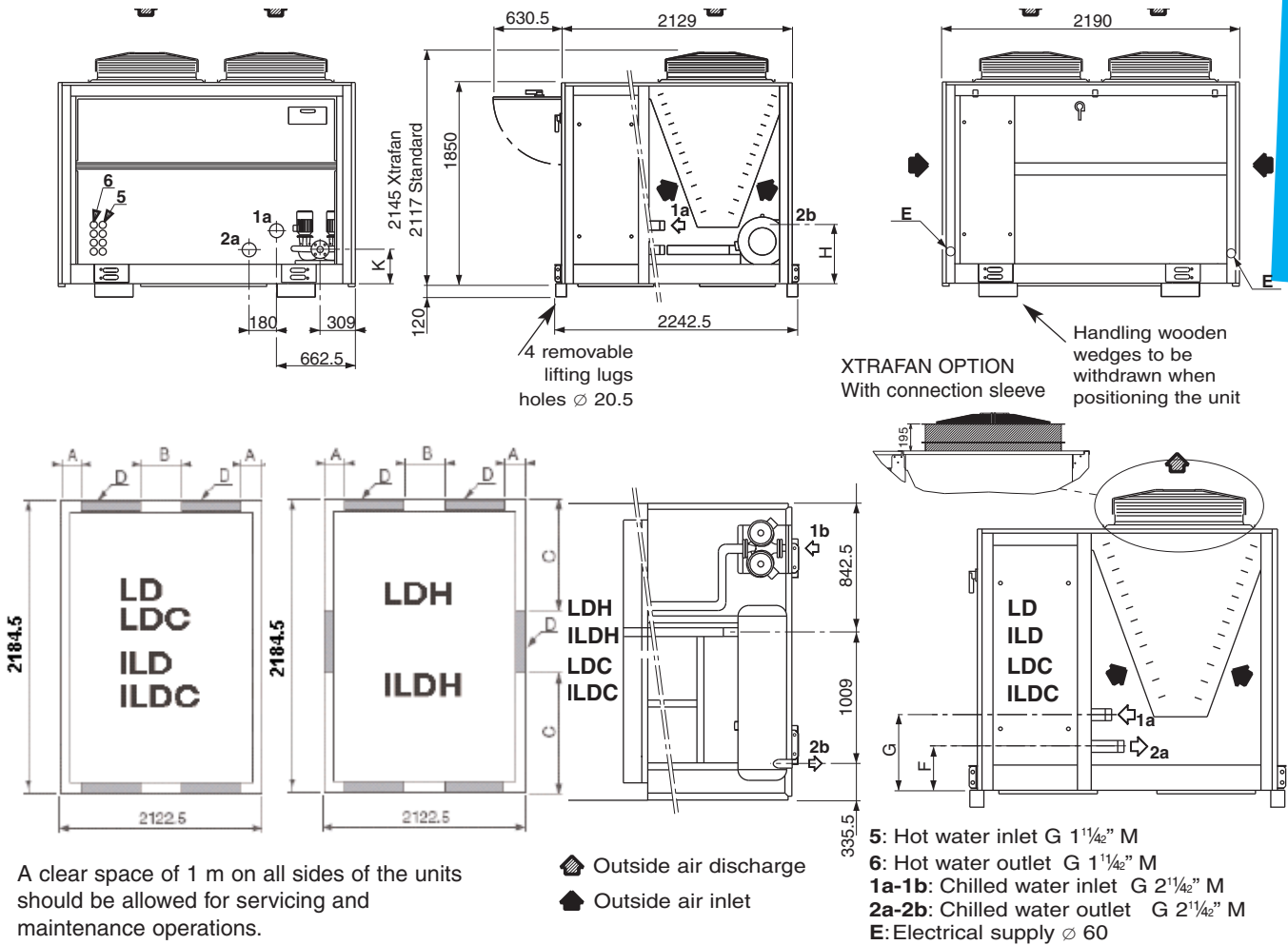

Sizes	K	Pump	Chilled water inlet	Chilled water outlet
LDC-ILDC	315	N°40-41-42-43	1a	2a
		N°117-217-118-218-119-219	1b	2a
LDH-ILDH	315	N°40-41-42-43	1a	2b
		N°117-217-118-218-119-219	1b	2b

Aquadat 2	Chilled water		Mounts position			Antivibration mounts		Mass in kg				
	Inlet	Outlet	A	B	C	D	no.	F	G	H	empty	in operation
LD 350	1a	2a	150	422.5		P25 50 x700	4	311	411		1046	1066
ILD 350											1096	1116
LD 400											1145	1165
ILD 400											1195	1215
LD 500											1183	1203
ILD 500	1283	1303										
LDC 350	See table above		150	422.5		P25 50 x700	4	311	411		1144	1164
ILDC 350											1194	1224
LDC 400											1242	1272
ILDC 400											1292	1322
LDC 500											1254	1275
ILDC 500	1355	1385										
LDH 350	See table above		150	422.5	742.25	P25 50 x700	6			548	1207	1477
ILDH 350											1257	1527
LDH 400											1306	1576
ILDH 400											1356	1626
LDH 500											1318	1588
ILDH 500	1418	1688										

DIMENSIONS

AQUACIAT 2 models 540 - 700

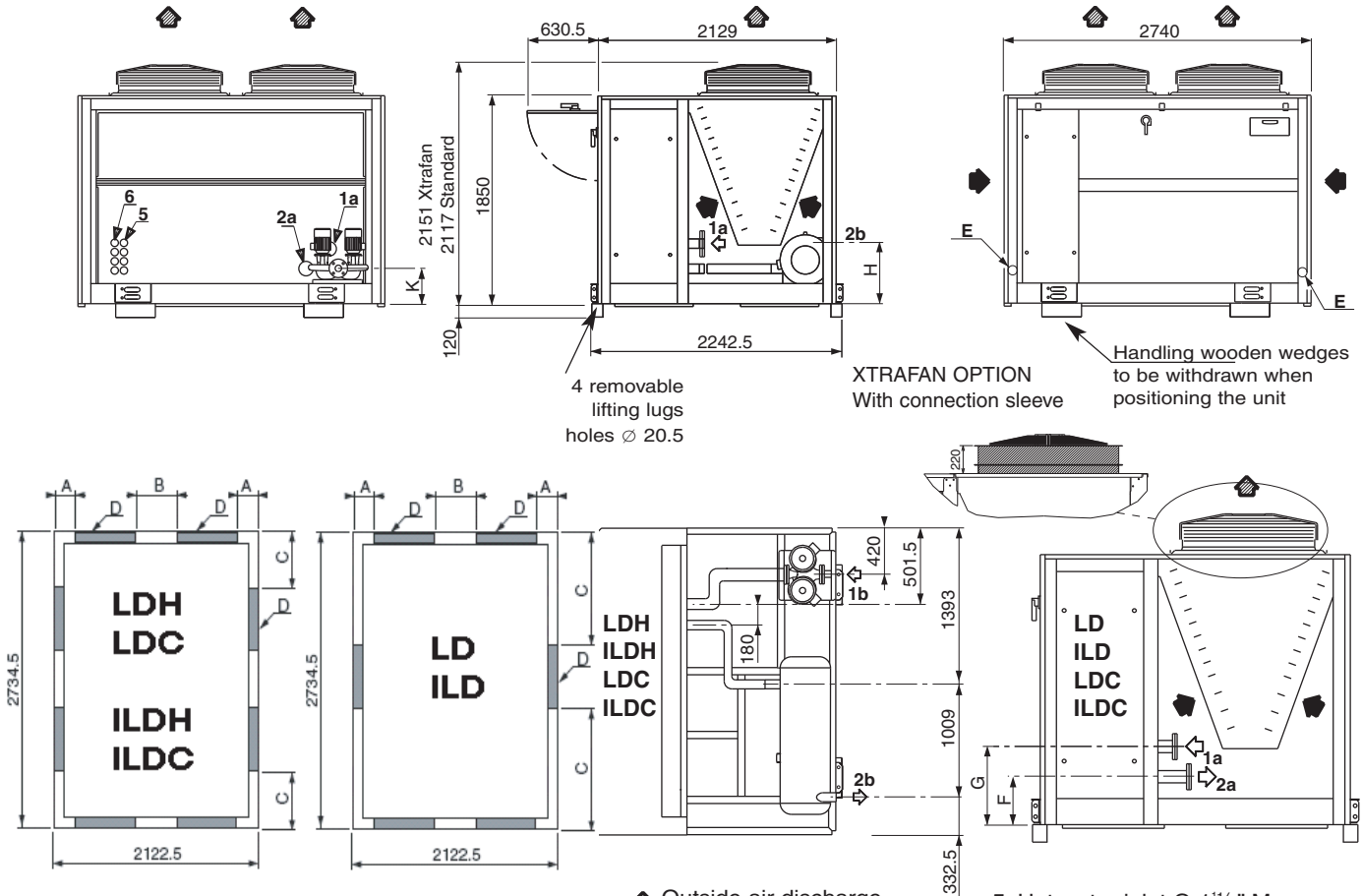

A clear space of 1 m on all sides of the units should be allowed for servicing and maintenance operations.

▣ Outside air discharge

▣ Outside air inlet

5: Hot water inlet G 1 1/4" M
6: Hot water outlet G 1 1/4" M

1a-1b: Chilled water inlet DN80
2a-2b: Chilled water outlet DN80

E: Electrical supply \varnothing 60

Size	K	Pump	Chilled water inlet	Chilled water outlet
LDC-ILDC		N°40-41-42-43	1a	2a
	315	N°117-217-118-218-119-219	1b	2a
LDH-ILDH		N°40-41-42-43	1a	2b
	315	N°117-217-118-218-119-219	1b	2b

Aquaciat 2	Chilled water		Mounts position			Antivibration mounts		F	G	H	Mass in kg	
	Inlet	Outlet	A	B	C	D	no.				empty	in operation
LD 540	1a	2a	150	422.5	1017.5	P25 50 x700	6	311	411	548	1460	1483
ILD 540											1570	1593
LD 600											1596	1621
ILD 600											1706	1731
LD 700											1768	1793
ILD 700											1878	1903
LDC 540											See table above	
ILDC 540	1675	1710										
LDC 600	1775	1810										
ILDC 600	1804	1839										
LDC 700	1947	1982										
ILDC 700	1976	2011										
LDH 540	See table above		150	422.5	445	P25 50 x700	8					
ILDH 540											1748	2028
LDH 600											1838	2118
ILDH 600											1868	2148
LDH 700											2010	2290
ILDH 700											2040	2320



DIMENSIONS

AQUACIAT 2 models 702 - 1100

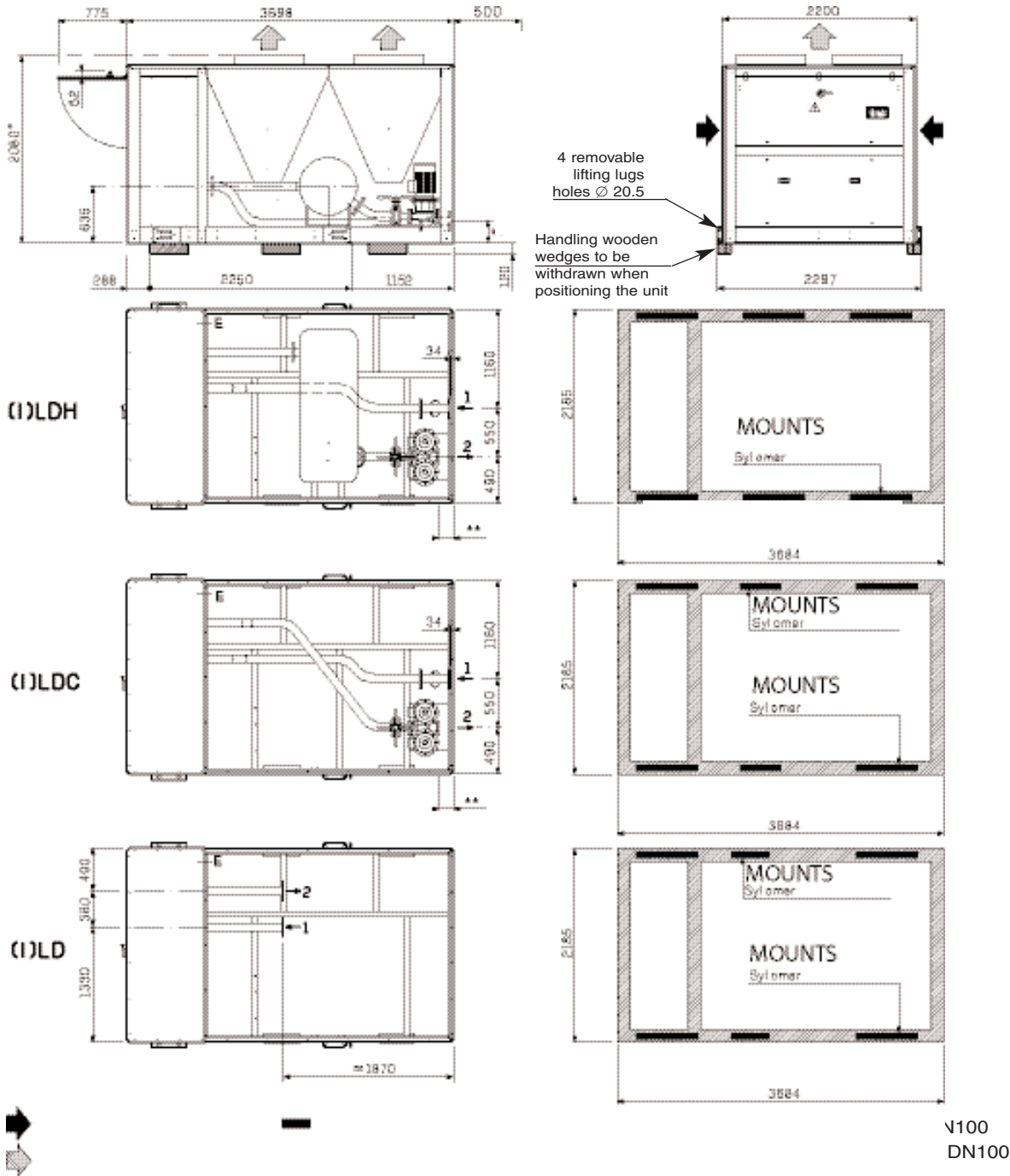

* 2285 mm Xtra Low Noise XLN model
 ** Depending on pump models

AQUACIAT		LD					LDC					LDH				
		702	800	900	1000	1100	702	800	900	1000	1100	702	800	900	1000	1100
Mass in kg	In operation	2170	2210	2250	2290	2345	2410	2450	2505	2545	2675	3080	3100	3155	3195	3295
	empty	2135	2175	2215	2255	2310	2360	2400	2455	2495	2625	2510	2550	2605	2645	2745

AQUACIAT		ILD					ILDC					ILDH				
		702	800	900	1000	1100	702	800	900	1000	1100	702	800	900	1000	1100
Mass in kg	In operation	2290	2340	2385	2465	2535	2580	2630	2685	2765	2875	3220	3270	3315	3395	3505
	empty	2270	2320	2365	2445	2505	2550	2600	2645	2725	2825	2680	2730	2775	2855	2955

GROUND FIXATION OF FRAME

AQUACIAT LD - LDC - LDH - ILD - ILDH

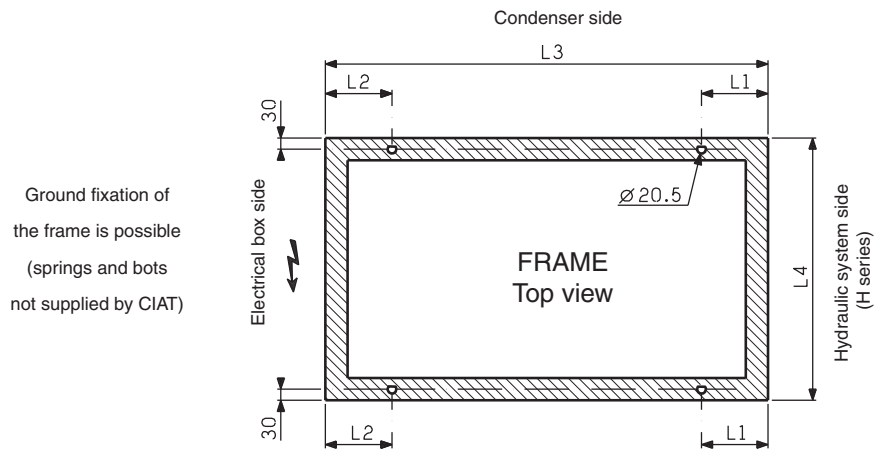

	80V	90V	100V	120V	150V	180V	200V	240V	300V	350V	400V	500V	540V	600V	700V	702V	800V	900V	1000V	1100V
L1			316					316			281			281				986.5		
L2			316					316			281			281				986.5		
L3			1984					1987			2122.5			2122.5				3684		
L4			1045					1044			2184.5			2184.5				2185		

EXAMPLES OF HYDRAULIC CONNECTION DIAGRAMS

Chilled water/hot water circuit

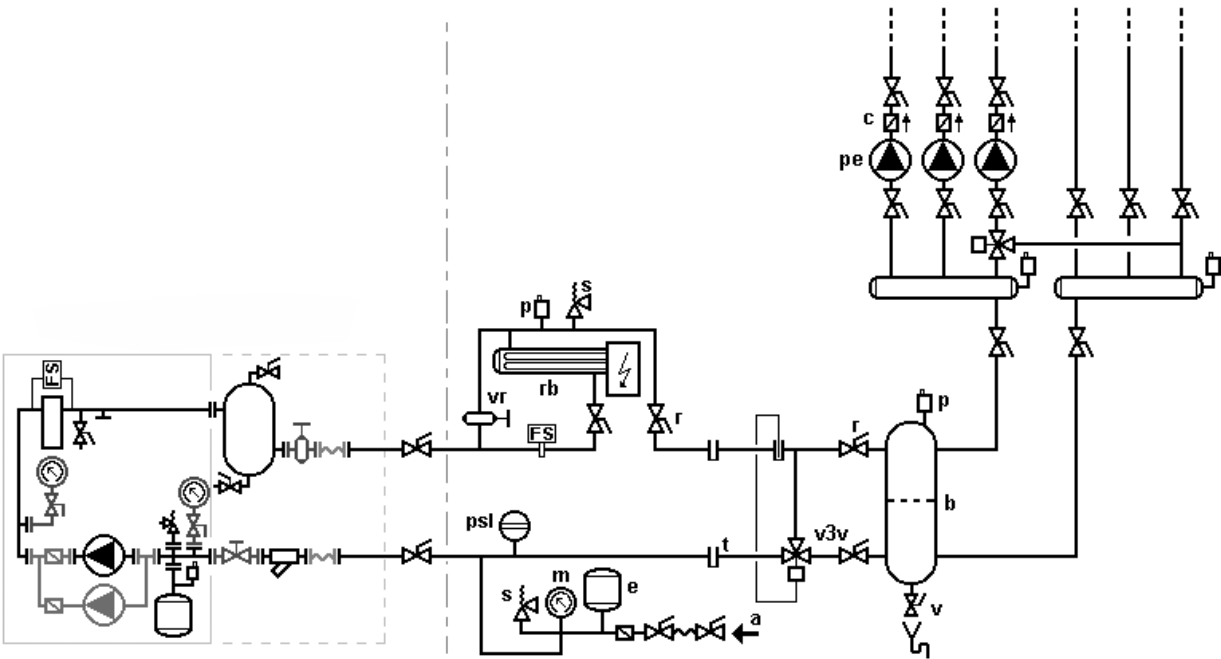

Hot water circuit with partial heat recovery (desuperheater)

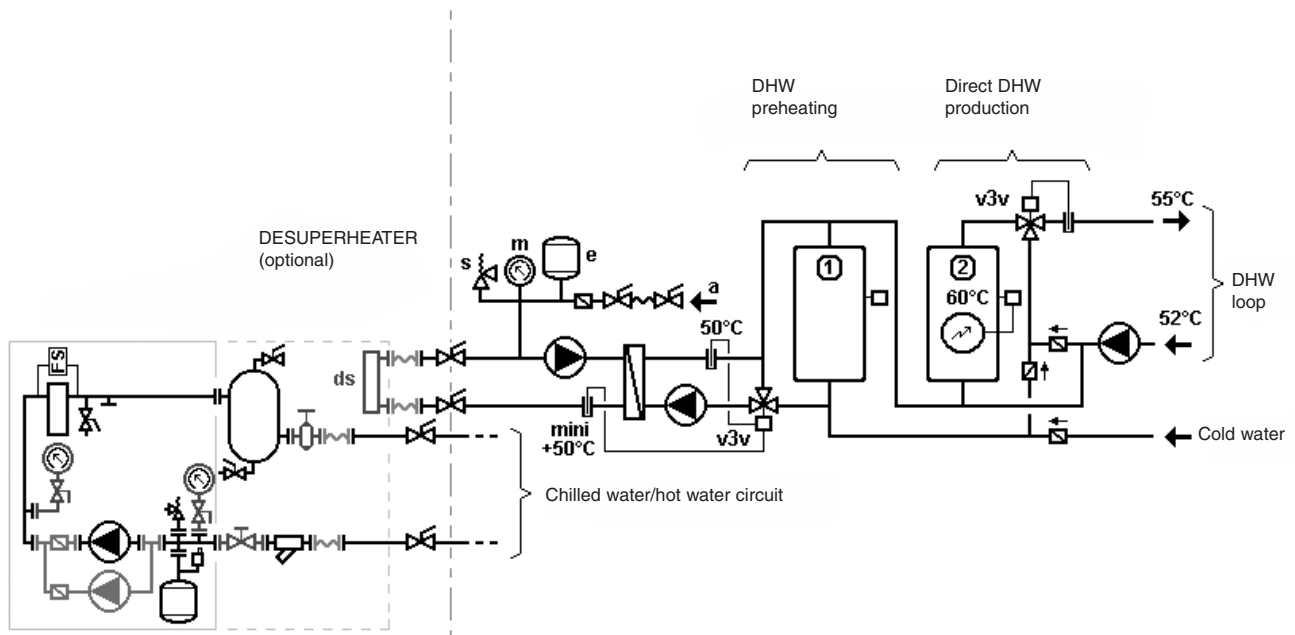

Note: the schematic diagrams herein are provided for information only. Under no circumstances do they constitute actual installation diagrams.

Note: the schematic diagrams herein are provided for information only. Under no circumstances do they constitute actual installation diagrams.

EXAMPLES OF HYDRAULIC CONNECTION DIAGRAMS

Hot water circuit with total recovery (water-cooled condenser)

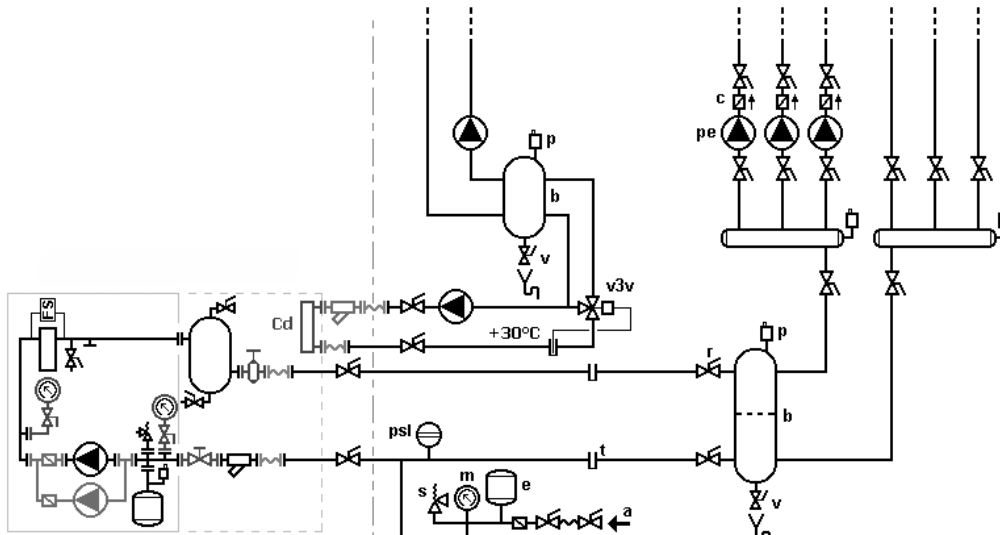

Chilled water circuit with COOL energy storage (parallel diagram)

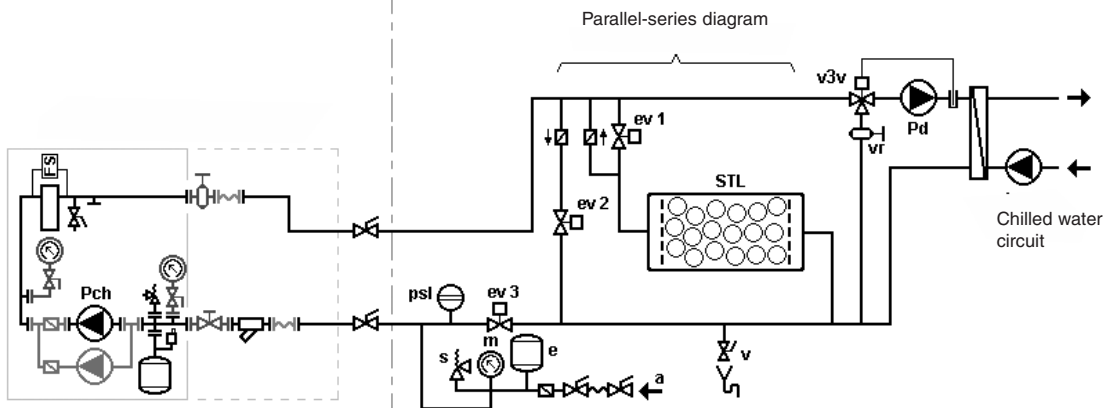

AquaCiat2: air-to-water reversible heat pump
 psl: pump water low pressure switch
 v3v: 3 way valve
 v2v: 2 way valve
 e: expansion tank
 c: check valve
 m: pressure gauge
 a: water supply
 b: mixing water tank
 r: stop valve :

vr: adjusting valve
 s: relief valve
 pe: water pump
 t: thermostatic sensor test bar
 rb: additional water heater
 FS: water flow switch
 ds: desuperheater
 STL: cold storage tank
 ev: solenoid valve
 Cd: water-cooled condenser

General comments:

p: air purge valves on pipe high points
 v: drain valves on pipe low points

Note: the schematic diagrams herein are provided for information only. Under no circumstances do they constitute actual installation diagrams.

Note: the schematic diagrams herein are provided for information only. Under no circumstances do they constitute actual installation diagrams.



Water chillers

- | | | | |
|-----------|-------------------------------------|-----|--------------------------------|
| AquaCiat2 | : air to water reversible heat pump | vr | : adjusting valve |
| psl | : pump water low pressure switch | s | : relief valve |
| v3v | : 3 way valve | pe | : water pump |
| v2v | : 2 way valve | t | : thermostatic sensor test bar |
| e | : expansion tank | rb | : additional water heater |
| c | : check valve | FS | : water flow switch |
| m | : pressure gauge | ds | : desuperheater |
| a | : water supply | STL | : cold storage tank |
| b | : mixing water tank | ev | : electrovanne |
| r | : stop valve | | |

In general:

- p : air purge ales on all pipes high points v : drain ales on all bottom points to extract water

Running principles depending the running mode	Position							
	Pd	Pch	ev1	ev2	ev3	v3v	GF	Control mode GF
Water circuit components								
Cold storage mode only	0	1	1	0	1	0	1	Night
Direct cooling mode	1	1	0	1	1	R	1	Day
Discharge only	1	0	0	0	0	R	0	-
Direct cooling + discharge	1	1	0	1	1	R	1	Day
Direct cooling + cold storage	1	1	1	0	1	R	1	Night

R -> Control ON

0 -> OFF

1 -> ON

Note: the above diagrams examples are only indicative and do not purport to show the installation details necessary.

AQUACIAT 2

Installation recommendations

■ Water quality criteria to be respected

Caution: A 800 microns water filter must be mounted on the machine water inlet during the installation phase.

The correct operation of the chilled/hot water production unit and a reasonable life expectancy depend directly upon the quality of the water used; make sure it is not causing scaling, corrosion, formation of algae or micro-organic growth.

An analysis of the water must be carried out to make sure that it is suitable for use in the unit; the analysis will also determine if a chemical treatment of the water results in an acceptable quality and if a water softening and demineralization system is necessary.

This analysis will confirm or not the compatibility of the water used on site with the following materials present on the circuit of this CIAT unit:

- 99.9% copper tubing with copper and silver brazing.
- Threaded bronze connectors or steel flat flanges depending upon models
- Stainless steel AISI 316-1.4401 plate heat exchangers with copper and silver brazing.

Caution: the non-respect of these instructions will immediately void the warranty of the chiller.

■ Lifting and handling operations

Lifting and handling operations must be carried out making sure the safety conditions are respected.

Refer and conform to the lifting diagram enclosed with the unit and to the Maintenance, Commissioning, Operating, Installation and Instructions brochure.

Before handling the unit, make sure that there is sufficient access to the room where the unit is to be installed.

Always maintain the unit in a vertical position; in no case should it lean or rest horizontally.

■ Positioning of the machine

The standard AQUACIAT 2 units are to be installed outdoors. Make sure they are protected against freezing.

For maintenance purposes, particular attention will be given to the space required, also above the unit.

The unit must be positioned on perfectly flat, horizontal, non combustible ground able to support the weight of the machine in operation.

The noise pollution of the auxiliary devices, such as pumps, is to be studied with care. Therefore, before positioning, study and treat, with the assistance of a sound technician if necessary, the various possible noise transmissions, depending upon the room and its structure.

The piping must be fitted with flexible connectors (supplied as an option)

In geographical areas with a risk of snowing up or white frost, heatpumps must be elevated approximately 300 mm above ground-level.

On reversible heat pumps, the water vapor and water from defrosting must be correctly evacuated during defrost cycles.



■ Installation inside technical plant

The possible installation in technical room supposes some technical care, in particular:

- The evacuation of the water produced during defrost cycles including during periods of very low outside temperatures,
- to assume the possible problem of the water vapor rejected at the fan discharge during defrost periods,
- a ground supporting the machine weight and perfectly watertight and able to collect then drain defrosting water, including during freezing periods,
- the weight of a discharge air duct shall never be supported by the roof of the machine.

In accordance with the regulations on the installation spot, a fresh air supply system may be installed in case of installation in a technical room, to avoid dangerous situation or no comfort in case of refrigerant leakage from the circuit of the machine.

■ Mounting of accessories delivered separately

Several optional accessories delivered separately can be mounted on the machine on site.

The instructions mentioned in the Installation, Operating, Commissioning and Maintenance brochure must be respected.

■ Electrical connections

The recommendations mentioned in the Maintenance manual must be respected.

All the instructions relating to the electrical connections are mentioned on the electrical diagrams enclosed with the unit (they must be strictly followed).

The connections must comply with good engineering practice and be carried out in accordance with norms and regulations in force.

Electrical wiring to be carried out on site:

- . main electric power supply,
- . remote control of the machine (if necessary)
- . free contacts information (optional).

It is important to note that the unit is not protected electrically against lightning.

Therefore appropriate protection devices will have to be planned and integrated on site in the electrical power box.

■ Piping connections

The Installation, Operating, Commissioning and Maintenance instructions manual must be respected.

Each pipe must be correctly aligned and sloped toward the installation drain valve. A reasonable servicing area must be kept for access to panels when mounting and connecting the pipes; the pipes will be thermally insulated.

Piping supports and braces must be independent in order to avoid vibrations and strain on the unit.

Isolating and water flow control valves must be planned when installing the unit.

- Pipe connections to be carried out on site:
 - . water supply with pressure reducing valve,
 - . evaporator, condenser and drain,
- Provide the accessories necessary for all hydraulic circuits, for example:
 - . a cooling water flow control thermostatic valve, mounted on the condenser water inlet or outlet (heatpump on HEATING mode),

- . a water expansion vessel,
- . drain holes on the lower parts of the pipes,
- . isolating valves with filter on the exchangers,
- . air vents at the high points of pipes,
- . check the installation water contents (plan a buffer tank if necessary),
- . flexible connections on the exchangers inlet and outlet,
- . manual water flow adjustment valves,
- . thermometers on each water inlet and outlet to allow the necessary controls when starting the unit or for maintenance purposes

Caution:

- Water circuit pressure should not exceed 4.0 bar,
- Position the expansion vessel before the water pump,
- Do not install any valve on the expansion vessel.
- Make sure the water circulating pumps are positioned right at the exchangers water inlet
- Make sure that the water pressure at the suction of each circulating pump is equal or higher than the minimum pressure NPSH required, particularly in case of an "open" type circuit.
- The water quality criteria have to be analyzed according to technical recommendations.
- Plan the necessary anti-frost protections for the unit and hydraulic installation, for example a possibility of draining the unit.
- The type and concentration of glycol, if used as a protection against freezing, must be checked before starting the unit.
- Before carrying out final hydraulic connections, the pipes should be rinsed with clean water to remove debris.

■ Start up

The commissioning of AQUACIAT 2 machines must be made by CIAT or by a company agreed by CIAT.

The recommendations of the Installation, Operating, Commissioning and Maintenance manual must be respected.

Non exhaustive list of operations to be carried out during commissioning:

- Check the correct location of the machine
- Verification of the electrical supply protection
- Verification of the phases and correct rotation direction
- Verification of the electrical connections on the unit
- Verification of correct sense of water circulation on the unit
- Verification of the water circuit cleanliness
- Water flow adjustment to the specified value
- Verification of the refrigeration circuit pressures
- Verification of the correct compressors rotation direction
- Verification of the water pressure drops and water flows
- Completion of running parameters check list

■ Maintenance operations

The machine requires specific preventive routine maintenance operations which must be provided by authorized service agents agreed by CIAT.

A report of the running parameters must be completed on a special "CHECK LIST" form to be returned to CIAT.

For this operation, refer to the Installation, Operating, Commissioning and Maintenance manual's instructions.

Take out a maintenance contract with a specialist on refrigerating machines agreed by CIAT, even during the period of warranty.



CONNECT2 CONTROL SYSTEM



80 to 300



350 to 1100

ERGONOMIC INTERFACE PANEL

- Multilanguage LCD (4 lines of 24 characters each)
- Reading of pressures and temperatures
- Operating state and fault diagnostics
- Master/slave management of two parallel-connected machines
- Fault memory management
- Pump management
- Programmable operation times

Volt-free contact card:

- Inputs:*
- Automatic operation control
 - Selection of setpoints 1/2
 - Setpoint adjustable via a 4-20 mA signal
 - Heating/cooling mode selection
 - Compressor load shedding

- Outputs:*
- General fault signalling
 - Pump control

RS-485 OUTPUT AS STANDARD

Open Modbus/Jbus protocol (standard)

LonWorks protocol (option)

Ethernet gateway (optional)

RELAY BOARD (OPTION)

Available outputs:

- Water flow fault
- Frost protection fault
- Pump fault
- Fan fault (air-to-water unit)
- Low and high pressure fault
- Compressor safety fault
- Discharge temperature fault
- Compressor operation fault

REMOTE-CONTROL UNIT (OPTION)

Same operation and design as local console

MULTICONNECT MULTI-UNIT MANAGEMENT (OPTION)

Main functions available:

- Management of up to 8 units on a single water loop
- Management in COOLING mode (water chiller) or HEATING mode (heat pump)
- Management of chilled-water or ho-water pumps
- Centralised management of a backup unit
- Unit load shedding
- System time programming
- Energy storage mode management
- Unit running time balancing
- Modbus/Jbus protocol RS485 output for BMS link

This document is non-contractual. As part of its policy of continual product improvement, CIAT reserves the right to make any technical modification it feels appropriate without prior notification.

Head office

Avenue Jean Falconnier - B.P. 14
01350 - Culoz - France
Tel.: +33 (0)4 79 42 42 42
Fax: +33 (0)4 79 42 42 10
info@ciat.fr - www.ciat.com



CIAT Service

Tel.: +33 (0)4 79 42 42 90
Fax: +33 (0)4 79 42 42 13

ISO9001 • ISO14001
OHSAS 18001



ISO9001 • ISO14001